

# HEATSEAL

## SHRINK PACKAGING SYSTEMS

### **MODEL CF-740** **CENTERFOLDER**



Shown As: CF-740 48" Centerfolder

**WILL FIT MOST SEMI-AUTOMATIC  
AND AUTOMATIC APPLICATIONS**

**REDUCE FILM COSTS OVER  
CENTERFOLDED FILM**

#### Features of the CF-740 Centerfolder

- 115 Volt Power Supply
- Variable And Reversible Power Film Drive
- Permits Running Single-Wound Film On Wrappers Designed For Centerfold Film
- Easy Access Service Panel
- Freestanding Design
- Long Wear, Replaceable Teflon Edge On Folding Plates
- Accommodates Roll Widths Of Up To 48"
- Durable Locking Casters For Portability
- Easy Load Film Cradle
- Heavy Duty, Stainless Steel Construction
- Self Aligning Attachment System
- Wider Model Available

## **TWO YEAR WARRANTY**

HEAVY DUTY SERIES

## Machine Specifications

<b>Film Capacity</b>	<b>48" (123 cm)</b>
<b>Maximum Roll Diameter</b>	<b>13" (33 cm)</b>
<b>Overall Dimensions</b>	<b>25" W, 60" L, 35" H</b> (64 W, 153 L, 90 H cm)
<b>Power Requirements</b>	<b>115V, 15 amp</b>
<b>Weight (Net)</b>	<b>350 lbs. (159 kg)</b>

**TWO YEAR WARRANTY**

## Machine Footprint

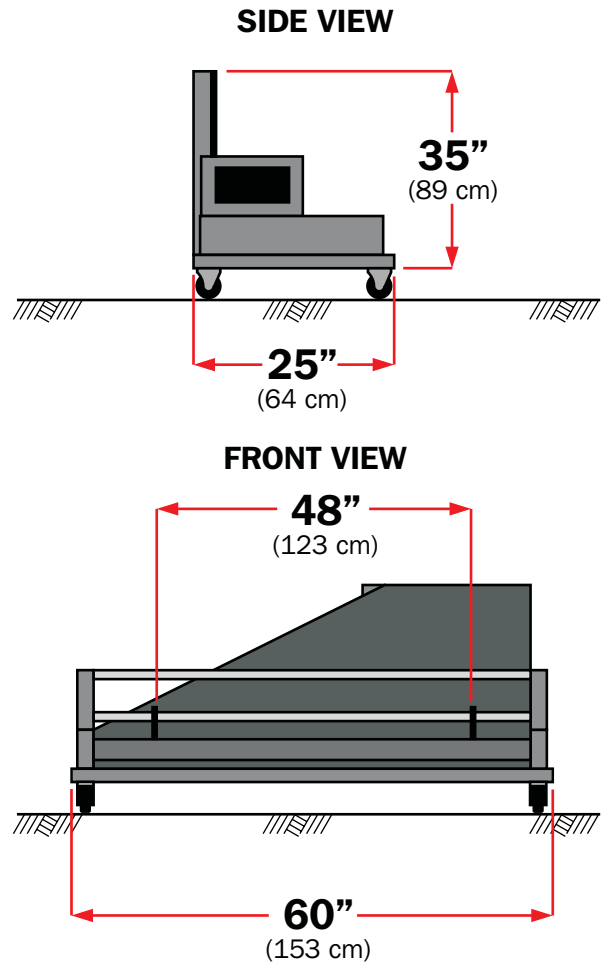

Dimensions above for CF-740

## Machine Options

- 220 Volt Power Supply
- Electronic Static Eliminator Bar

For Additional Product Information, Contact:



**HEAT SEALING EQUIPMENT LLC**  
4580 EAST 71ST STREET CLEVELAND, OHIO 44125

PHONE (216)341 2022 TOLL FREE (800)342 6329 FAX (216)341 2163  
WORLD WIDE WEB [www.heatsealco.com](http://www.heatsealco.com) E-MAIL [custserv@heatsealco.com](mailto:custserv@heatsealco.com)

