

# HEATSEAL

## SHRINK PACKAGING SYSTEMS

### MODEL HDS-1524

#### HEAVY DUTY L SEALER



**HEAVY DUTY CONSTRUCTION  
THROUGHOUT**

**STANDARD IMPULSE WIRE OR  
HOT KNIFE SYSTEM AVAILABLE**

#### Features Available on the HDS-1524

- Standard 115 Volt Power Supply With GFI Protection
- Standard Microprocessor Acc-U-Seal Wire Temperature Control
- Top Mounted, Easy Access U.L. Listed Control Panel (File No. E146586)
- Large 15" Wide By 24" Long Seal Area
- Cast Aluminum Seal Head Design With Film Clamps
- Easily Adjustable Seal Arm Height
- Adjustable Seal Pads
- Film Separator Rod
- Film Perforator With Individually Adjustable Collars
- Adjustable Film Cradle
- Stainless Steel Product Loading Tray
- Posi-Trac Power Take Away Conveyor With Adjustable Speed Control
- Dual Magnets With Adjustable Pressure And Dwell Time
- Heavy Duty Circuit Breaker On / Off Switch
- Console Unit With Heavy Duty Adjustable Levelers And Casters
- Stainless Steel Model Available
- Shipped Set Up And Ready To Use

## TWO YEAR WARRANTY

HEAVY DUTY SERIES

## Machine Specifications

<b>Film Capacity</b>	<b>20" Wide (51 cm)</b>
<b>L Bar Seal Area</b>	<b>15" W, 24" L (38 W x 61 L cm)</b>
<b>Overall Dimensions</b>	<b>59" H, 31" W, 57" L (150 H, 99 W, 145 L cm)</b>
<b>Working Height</b>	<b>35" (89 cm)</b>
<b>Power Requirement</b>	<b>115 Volts, 15 Amp Single Circuit w/Ground</b>
<b>Weight</b>	<b>460 lbs. (209 kg)</b>

## Machine Footprint

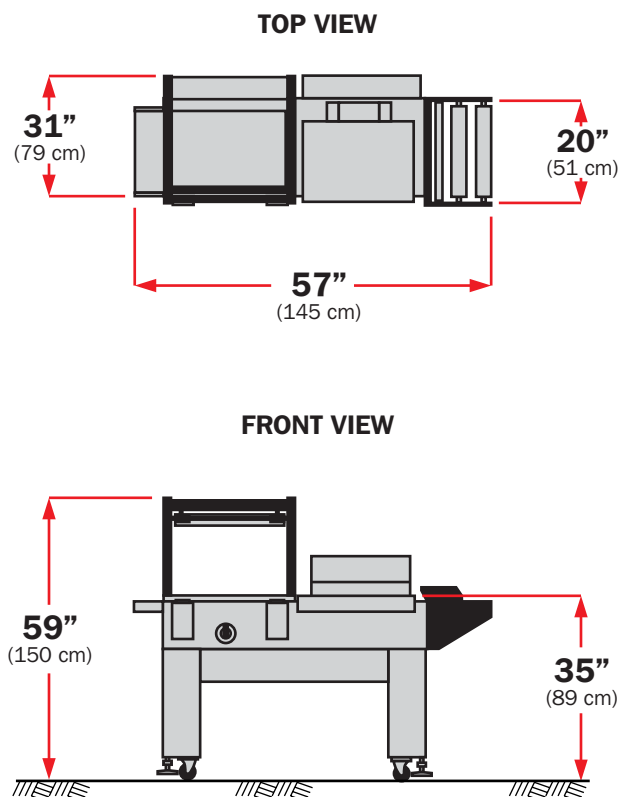

**TWO YEAR WARRANTY**

## Machine Options

- Heated Hole Punch
- Adjustable Heated Hole Punch With Articulated Arm
- Roller Drip Pan Or Corrugated Loading Tray
- Heat Seal Hot Knife With Digital Temperature Controls
- Reynolds Duo Seal Hot Knife With Digital Temperature Controls
- Beaded Seal Impulse Wire Seal System
- Powered Lift / Posi-Trac Power Take Away Conveyor
- Variable Speed Soft-Start Power Take Away Control
- Powered Film Unwind With Perforating Roller And Adjustable Height Inverting Head
- Air Activated Seal Head With Emergency Stop
- Dual Film Rack
- Left Hand Reverse Flow
- Export Wire: 220 Volts
- Special Paint Color
- Stainless Steel Construction
- Spare Parts Kit

For Additional Product Information, Contact:



**HEAT SEALING EQUIPMENT LLC**  
4580 EAST 71ST STREET CLEVELAND, OHIO 44125

PHONE (216)341 2022 TOLL FREE (800)342 6329 FAX (216)341 2163  
WORLD WIDE WEB [www.heatsealco.com](http://www.heatsealco.com) E-MAIL [custserv@heatsealco.com](mailto:custserv@heatsealco.com)



MODEL HDS-1524 HEAVY DUTY SERIES