

HEAT SEAL

SHRINK PACKAGING SYSTEMS

MODEL HDTC-4822A

HEAVY DUTY CONVECTION SHRINK TUNNEL



**TEN YEAR
HEATING ELEMENT
WARRANTY**

Features Available on the HDTC-4822A

- Heavy Duty, Heavy Gauge Construction Throughout
- Variable Air Velocity Control
- Adjustable Chamber Height For Greater Efficiency
- Large Viewing Window With Infra-Red Reflecting Glass
- 12,000 Watt Heating Elements
- Automatic Cool Down Extends Heating Element Life
- Adjustable Conveyor Height
- Pull Out Electrical Console For Easy Servicing
- Acc-U-Temp Digital Temperature Control
- High Tech Adjustable Safety Torque Control Allows Conveyor To Stall If Jammed With No Harm To The Motor
- Center Drive Conveyor Belt
- Easy Change Reversible Conveyor Flow
- Stainless Steel Wire Mesh Belt or Live/Dead Roller Conveyor
- Heavy Duty Adjustable Console With Levelers And Casters
- Stainless Steel Model Available

THREE YEAR WARRANTY

HEAVY DUTY SERIES

Machine Specifications

Inside Chamber Dimensions	12" H, 26" W, 48" L (21 H, 66 W, 122 L cm)
Overall Dimensions	66" H, 38" W, 75" L (168 H, 96 W, 191 L cm)
Working Height	34" to 38" (86 to 97 cm)
Net Weight	
Conveyor Speed	0-60 Feet Per Minute (SWB)
Power Requirements	208-240 Volts, 30 Amps Three Phase Circuit
Wattage	12,000 Watts
Heating Element Warranty	Ten Year

THREE YEAR WARRANTY

Machine Footprint

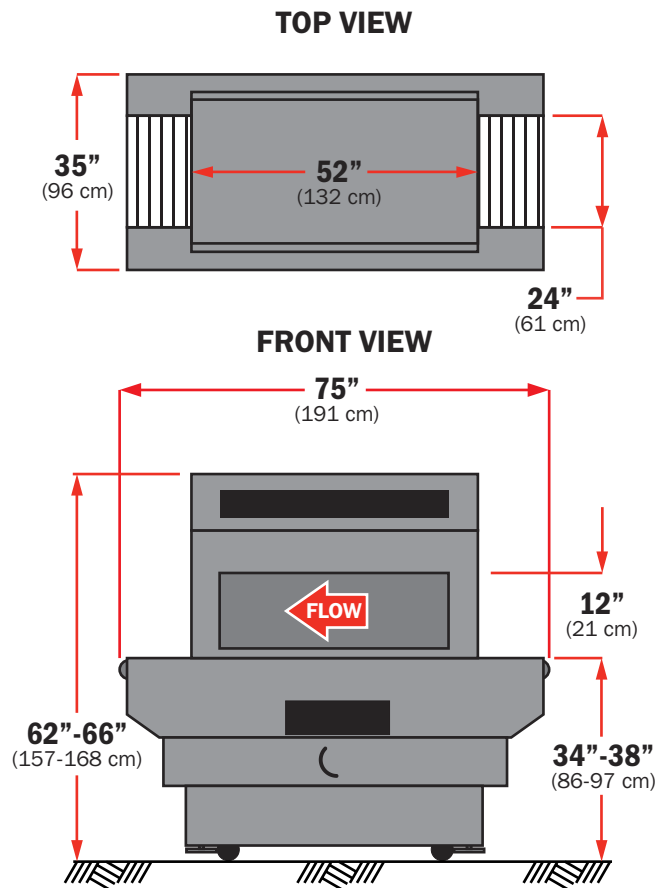

Machine Options

- Stainless Steel Model
- High Speed Gearing

For Additional Product Information, Contact:



HEAT SEALING EQUIPMENT LLC

4580 EAST 71ST STREET CLEVELAND OHIO 44125
(216) 341 2022 (800) 342 6329 FAX (216) 341 2163

WEBSITE www.heatsealco.com E-MAIL custserv@heatsealco.com

