

**HEATSEAL**

**SHRINK PACKAGING SYSTEMS**

**MODEL T-110**

**SHRINK TUNNEL**



Shown As: T-110 With Silicone Belt

**115 VOLT  
COMPACT, TABLE TOP  
SHRINK TUNNEL**

### Features of the T-110 Shrink Tunnel

- 115 Volt / 2000 Watt Shrink Tunnel
- High Velocity Turbo Design
- 6" High By 15" Wide Tunnel Opening
- High Quality Calrod Heating Element
- Constant Speed
- Silicone Covered Fiberglass Belt Conveyor
- Easy To Use Controls
- Heavy Gauge Steel Construction
- Stainless Steel Model Available
- Shipped Set Up And Ready To Use

**TWO YEAR WARRANTY**

STANDARD DUTY SYSTEMS

## Machine Specifications

<b>Inside Tunnel Dimensions</b>	<b>6" H, 15" W, 20" L</b> (15 H, 38 W, 51 L cm)
<b>Overall Dimensions</b>	<b>21" H, 20" W, 29" L</b> (53 H, 51 W, 74 L cm)
<b>Weight (Net)</b>	<b>98 lbs.</b> (45 kg.)
<b>Power Requirement</b>	<b>115 Volts, 20 Amps</b> <b>Single Circuit w/Ground</b>
<b>Wattage</b>	<b>Tunnel: 2,000 Watts</b>
<b>Conveyor</b>	<b>Constant Speed</b> <b>Silicone Belt</b>

**TWO YEAR WARRANTY**

## Machine Footprint

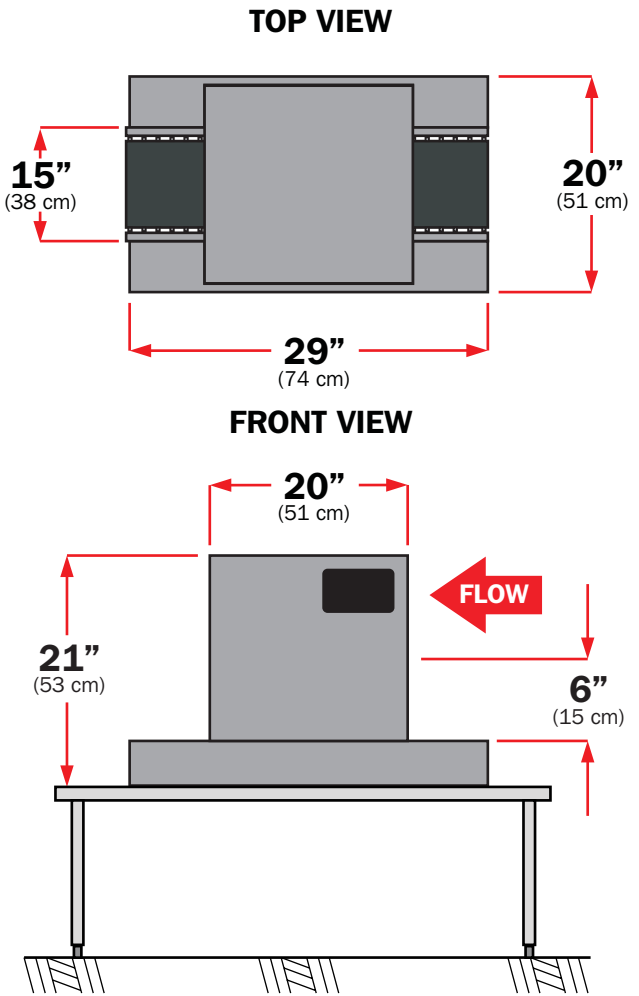

Recommended L Sealer: HS-1515

## Machine Options

- Automatic Cool Down
- Gravity Discharge Conveyor
- Export Wiring
- Stainless Steel Construction
- Special Paint Color

For Additional Product Information, Contact:



**HEAT SEALING EQUIPMENT LLC**  
4580 EAST 71ST STREET CLEVELAND, OHIO 44125



PHONE (216)341 2022 TOLL FREE (800)342 6329 FAX (216)341 2163  
WORLD WIDE WEB [www.heatsealco.com](http://www.heatsealco.com) E-MAIL [custserv@heatsealco.com](mailto:custserv@heatsealco.com)