

REVISION HISTORY				
REV	ECN	BY	DATE	DESCRIPTION
1	1204	TLB	7/15/2005	ADDED ITEM #5 - SPACER
2	2767	JPR	7/26/2011	DELETED (1) 5818-319, 2170-060 WAS 2170-050
3	3247	EMT	12/22/2015	REPLACED 1903-593 WITH 1903-808

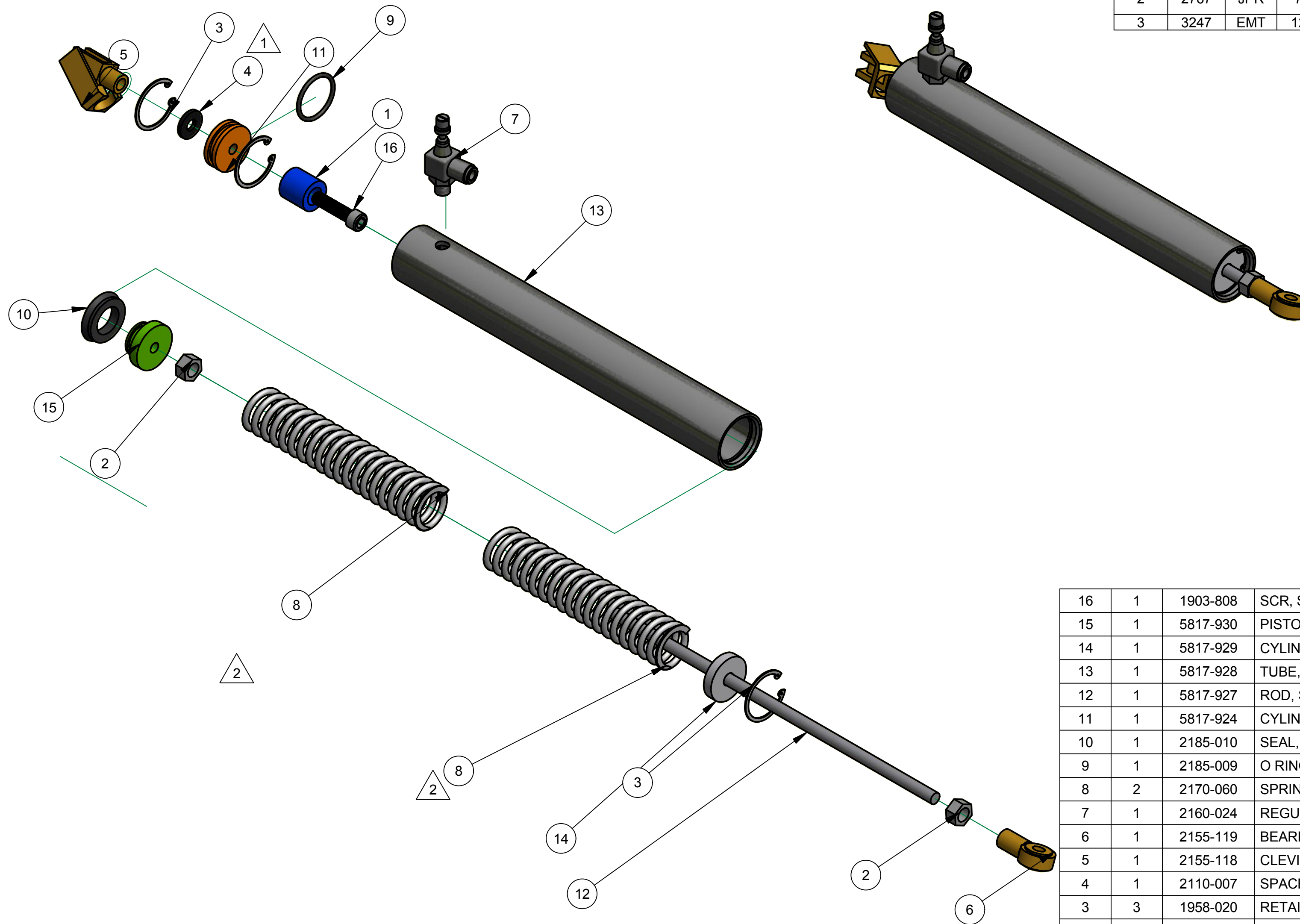

16	1	1903-808	SCR, SOCKET HD, 5/16-24 x 1 1/4 LG
15	1	5817-930	PISTON, SPRING CYLINDER CUPSEAL
14	1	5817-929	CYLINDER END, SHAFT
13	1	5817-928	TUBE, SPRING CYLINDER
12	1	5817-927	ROD, SPRING CYLINDER
11	1	5817-924	CYLINDER END, MOUNT
10	1	2185-010	SEAL, U-CUP 1 -1/4OD X 3/4 ID, 70 DURO BUNA-N
9	1	2185-009	O RING, 1 1/4 OD X 1 1/16ID, 70 DURO BUNA N
8	2	2170-060	SPRING, COMP, 1.218 OD X 0.162 WD X 6.00 FL, 51 LBS/IN
7	1	2160-024	REGULATOR, FLOW
6	1	2155-119	BEARING, ROD END, FEMALE, PTFE
5	1	2155-118	CLEVIS, ROD W/PIN, MACHINED, ST
4	1	2110-007	SPACER, NYLON, BLK - 5/16 ID X 3/4 OD X 3/32 THK
3	3	1958-020	RETAINER, RING, HOUSING, ST, INTERNAL
2	2	1911-107	5/16 -24 FINISHED HEX NUT
1	1	0910-027	BUMPER, RUBBER, W/WASHER, 13/16OD X 13/16 LG
ITEM	QTY	PART NO.	DESCRIPTION

Material List

ALL DIMENSIONS IN INCHES EXCEPT WHERE NOTED STANDARD TOLERANCES EXCEPT WHERE NOTED (ALL PLUS/MINUS) 2 PLC. DECIMAL: .010 3 PLC. DECIMAL: .005 FRACTION: 1/32 ANGLE: 1'	DWG BY: TLB DATE: 8/29/2006		HEAT SEAL/AMPAK CLEVELAND, OHIO 44125	
	CHK'D BY: DATE:			
	USED ON: HDS-1524		DESCRIPTION: SPRING CYLINDER ASSY, HVY DUTY	
	SHEET SIZE: C	SHEET: 1 OF: 1	DRAWING NO. 5818-318	REVISION: 3
PART FILE NAME: C:_Vault Working Folder\Heat Seal Vault\Products\Industrial\L-Sealers\HDS-3040S\5818-318.iam				