

REVISION HISTORY				
REV	ECN	DATE	DONE BY	DESCRIPTION
1	N/A	12/3/2015	MJA	MATCHING VAULT REVISION
2	3247	12/22/2015	EMT	REPLACED 1903-593 WITH 1909-808

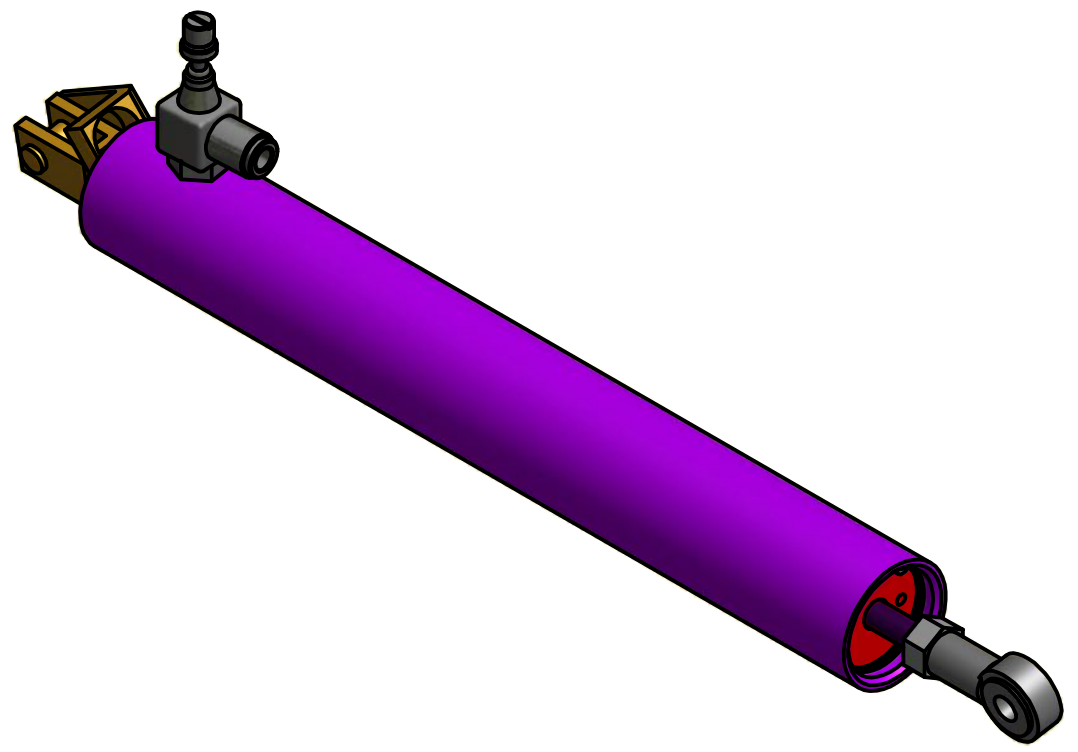
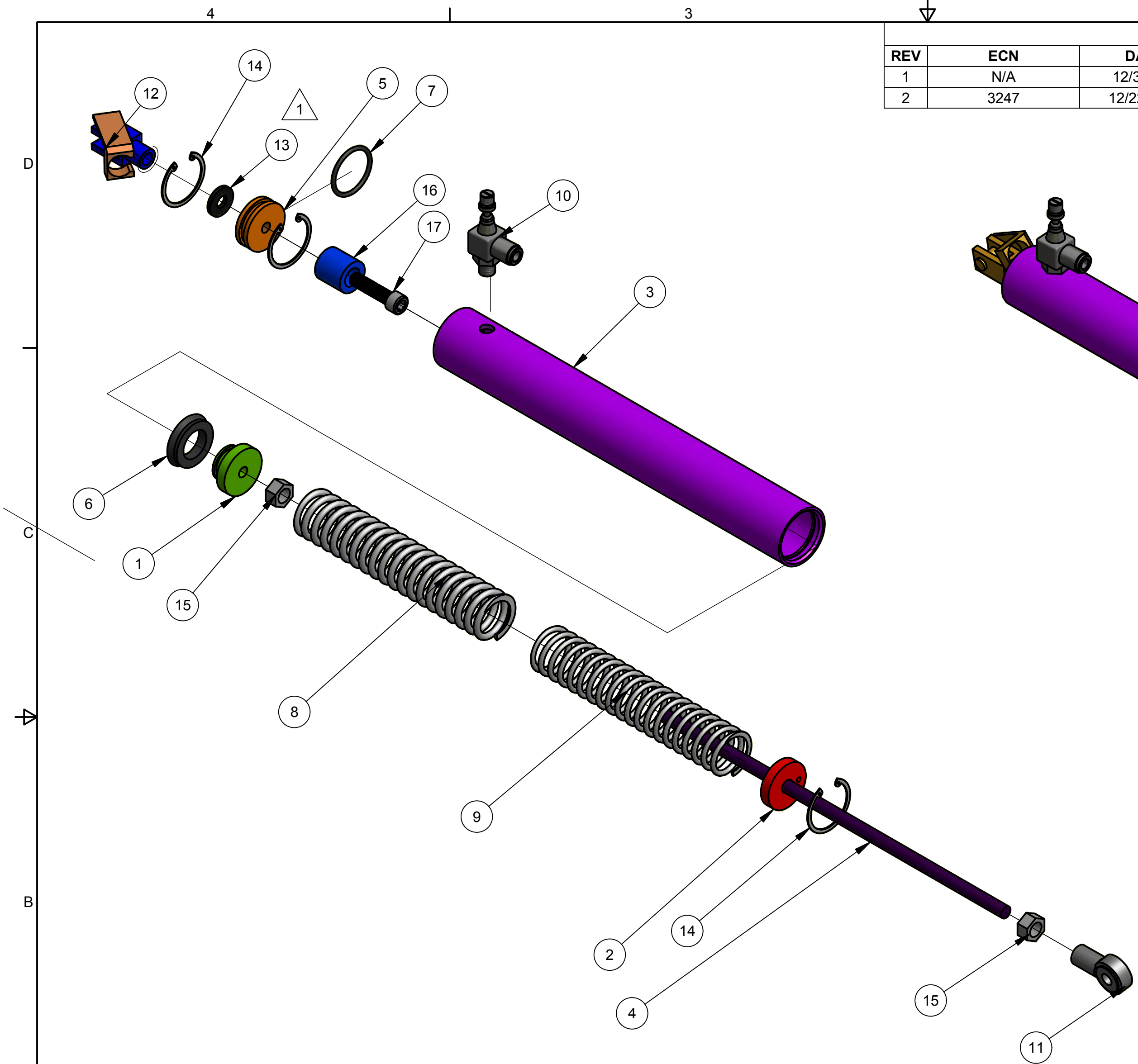

17	1	1903-808	SCR, SOCKET HD, 5/16-24 x 1 1/4 LG
16	1	0910-027	BUMPER, RUBBER, W/WASHER, 13/16OD X 13/16 LG
15	2	1911-107	5/16 -24 FINISHED HEX NUT
14	3	1958-020	RETAINER, RING, HOUSING, ST, INTERNAL
13	1	2110-007	SPACER, NYLON, BLK - 5/16 ID X 3/4 OD X 3/32 THK
12	1	2155-118	CLEVIS, ROD W/PIN, MACHINED, ST
11	1	2155-119	BEARING, ROD END, FEMALE, PTFE
10	1	2160-024	REGULATOR, FLOW
9	1	2170-050	SPRING, COMPRESSION, MW, 37.7 LBS/IN
8	1	2170-060	SPRING, COMP, 1.218 OD X 0.162 WD X 6.00 FL, 51 LBS/IN
7	1	2185-009	O RING, 1 1/4 OD X 1 1/16ID, 70 DURO BUNA N
6	1	2185-010	SEAL, U-CUP 1 -1/4OD X 3/4 ID, 70 DURO BUNA-N
5	1	5817-924	CYLINDER END, MOUNT
4	1	5817-927	ROD, SPRING CYLINDER
3	1	5817-928	TUBE, SPRING CYLINDER
2	1	5817-929	CYLINDER END, SHAFT
1	1	5817-930	PISTON, SPRING CYLINDER CUPSEAL
ITEM	QTY	PART NO.	DESCRIPTION

Material List

HEAT SEAL/AMPAK
CLEVELAND, OHIO 44125

CONFIDENTIAL
THIS PRINT IS PROPERTY OF, AND DISCLOSES PROPRIETARY INFORMATION OF HEAT SEAL. IT IS LOANED FOR REFERENCE ONLY, AND MAY NOT BE REPRODUCED OR FORWARDED ELECTRONICALLY IN ANY MANNER, OR ITS CONTENTS DISCLOSED TO OTHERS, WITHOUT THE EXPLICIT WRITTEN PERMISSION OF OWNER AND MUST BE DESTROYED UPON REQUEST.

UNLESS OTHERWISE SPECIFIED:
ALL DIMENSIONS IN INCHES
STANDARD TOLERANCES:
0.00: ± .010
0.000: ± .005
ANGLE: ± 1'

CREATED: 3/4/2015
CREATED BY: slazor
CHECKED: 3/26/2015
CHECKED BY: JFEASTER

DESCRIPTION:
SPRING CYLINDER ASSEMBLY

DRAWING NUMBER: **5820-429** REVISION: **2**

SIZE: C SCALE: NONE SHEET: 1 OF: 1