

ECN #	REV.	BY	DATE	REVISION HISTORY
	4	DAF	2/11/02	CHANGED FROM WELDED TO PINNED, REDRAWN IN CAD

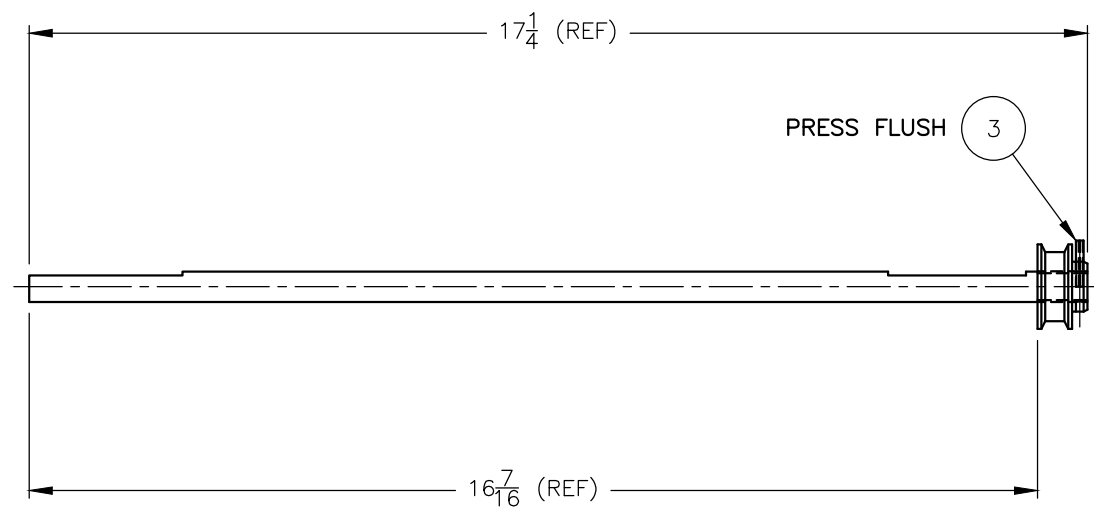
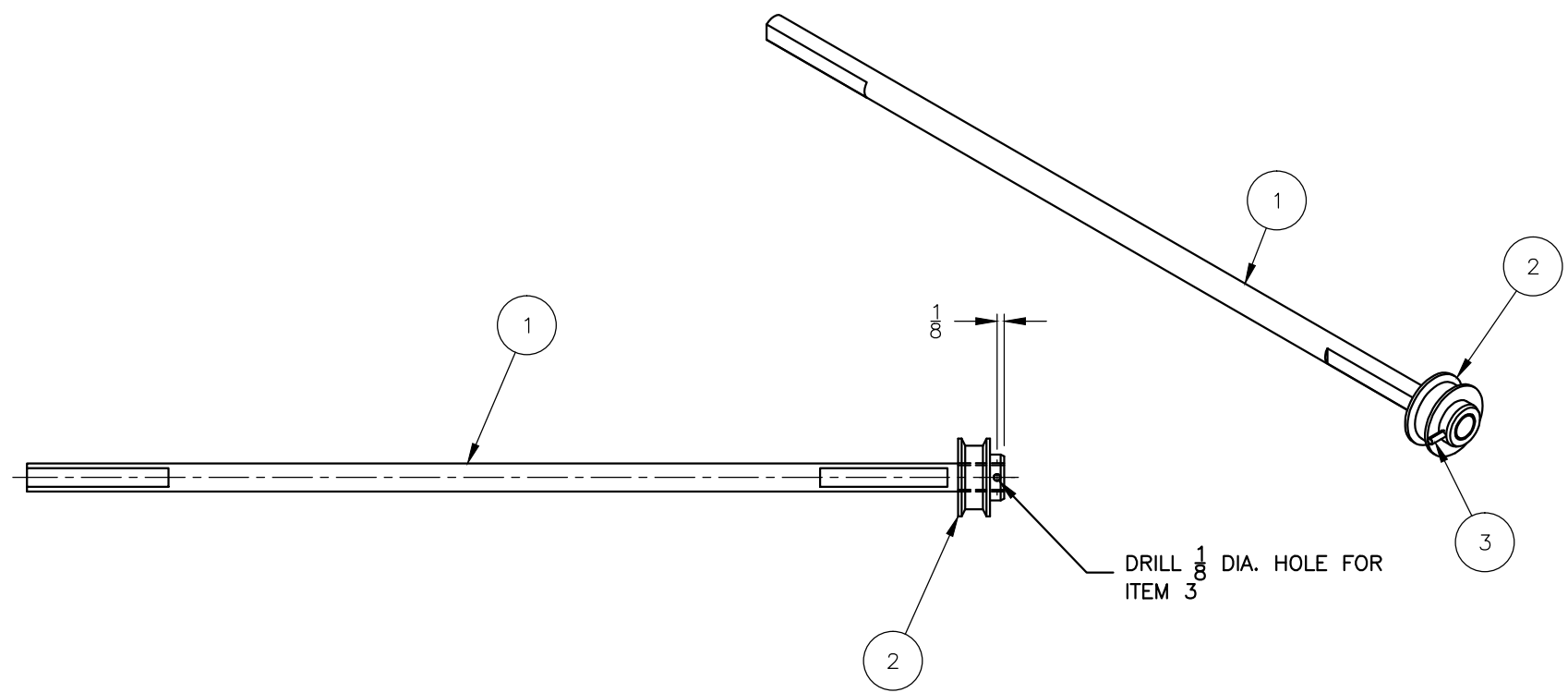

ASSEMBLE IN MACHINE SHOP

ITEM	QTY.	PART NO.	DESCRIPTION
3	1	1921-016	
2	1	2175-007	
1	1	6003-039	

PARTS LIST			
C	DWG. BY: DAF	HEAT SEAL	HEAT SEALING EQUIPMENT MFG. CO. 4580 East 71st Street Cleveland, Ohio 44125-1018
	DATE: 2/11/02		
ALL DIMENSIONS IN INCHES EXCEPT WHERE NOTED		DESCRIPTION	
TOLERANCE EXCEPT WHEN NOTED		SHAFT ASSEMBLY, DRIVE TUNNEL CONVEYOR	
DECIMAL	FRACTIONAL	SCALE 1/2	SHEET 1 OF 1
.X±0.03	± 1/32	MODEL HS-115	REVISION 4
.XX±0.010	ANGULAR	DWG. NO. 6003-074	
.XXX±0.005	± 1°-0'		

MATERIAL: SEE PARTS LIST

FINISH: BLACK OXIDE

QTY./UNIT: ONE

CUT SIZE: WEIGHT:

SYMBOL LEGEND	
//	PARALLEL WITHIN
⊥	PERPENDICULAR TO
∠	ANGLE HELD TO
—	STRAIGHT WITHIN
REFERENCE NO.	6003-272