

REVISION HISTORY				
REV	ECN #	DATE	BY	DESCRIPTION
0	2585	7/15/2010	TMM	INITIAL RELEASE
1	2985	7/3/2013	JPR	RIVNUT 1911-024 WAS MOVED TO BASE ASSY 6501-050
2	4155	11/5/2020	NS	REPLACED 6501-041 WITH 6501-086

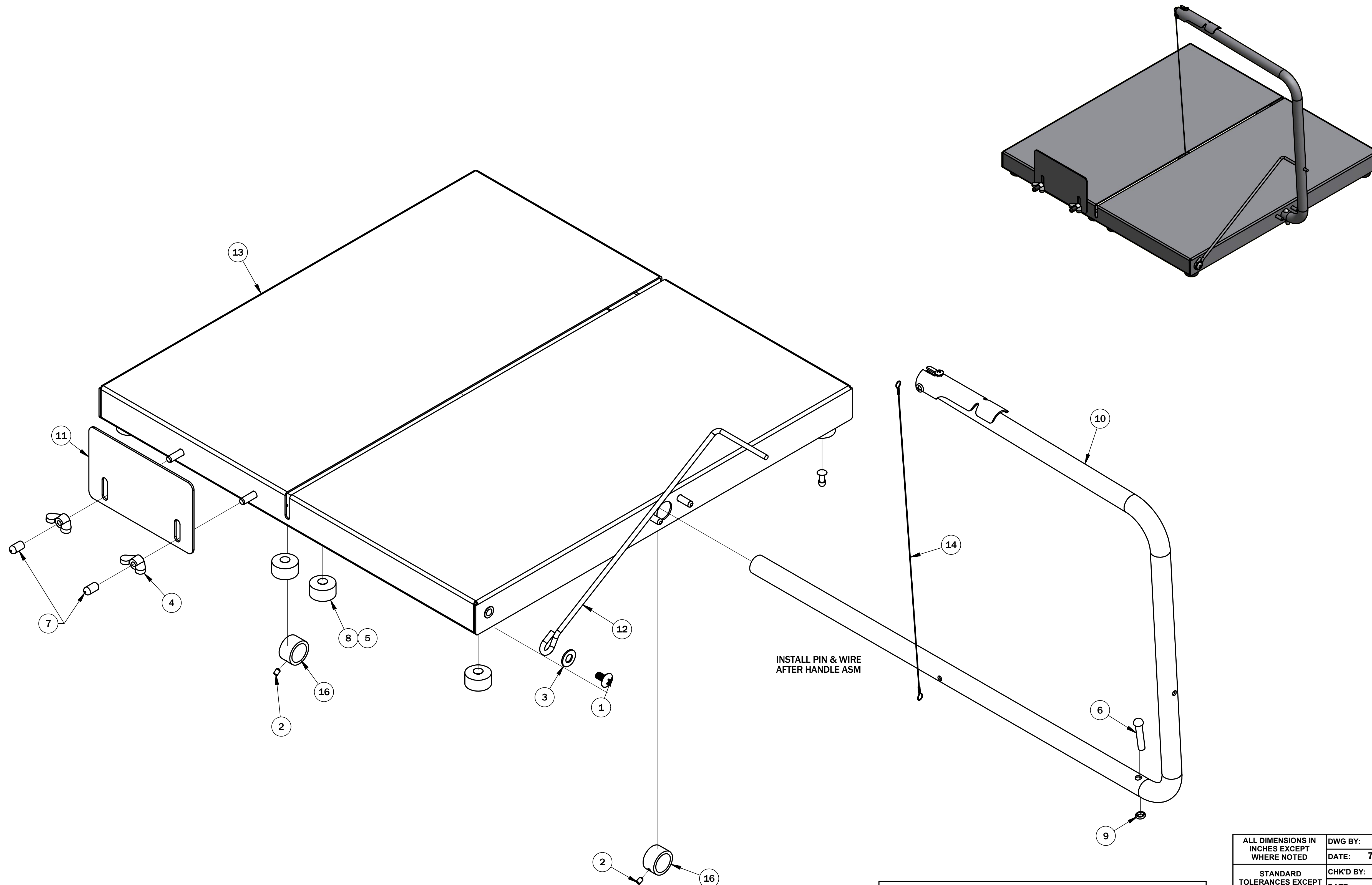

ITEM	QTY	PART NO.	DESCRIPTION
16	2	6501-086	COLLAR, LOCATING BOW
15	1	6501-019	RIVET, SS, RD HD, #10 X 1" LG
14	1	6501-072	WIRE, CHEESE CUTTER, CC20
13	1	6501-050	BASE, CHEESE CUTTER, WELD ASSEMBLY
12	1	6501-048	ROD, LOCKING ARM
11	1	6501-045	PLATE, FRONT, CHEESE CUTTER
10	1	6501-015	HANDLE ASSEMBLY
9	1	2185-001	O-Ring, 1/4 ID
8	8	2135-001	FOOT, RUBBER, 1" OD
7	2	1970-001	Cap, Rubber Luster, 1/4
6	1	1913-015	RIVET, SS, RD HD, SOLID
5	8	1913-006	RIVET, POP, ALUM/ALUM, #66
4	2	1911-022	Wing Nut, 1/4-20
3	1	1909-006	WASHER, FLAT, 5/16
2	2	1905-008	SCR,SET,CUP,SS #8-32 X 1/4" LG
1	1	1903-057	SCR, MACH, TRUSS HD, PHIL, SS, 1/4-20 x 5/8 LG

PARTS LIST				
ALL DIMENSIONS IN INCHES EXCEPT WHERE NOTED	DWG BY: TMM	<b>HEAT SEAL/AMPAK</b> CLEVELAND, OHIO 44125		
STANDARD TOLERANCES EXCEPT WHERE NOTED (ALL PLUS/MINUS)	DATE: 7/14/2010			
2 PLC. DECIMAL: .010	CHK'D BY:	DESCRIPTION: <b>CHEESE CUTTER, 20 X 20</b>		
3 PLC. DECIMAL: .005	DATE:			
FRACTION: 1/32	USED ON: CC20	SHEET: 1 OF 1	DRAWING NO. <b>6501-002</b>	REVISION: <b>2</b>
ANGLE: 1'	SHEET SIZE: <b>D</b>	DO NOT SCALE PRINT		PART FILE NAME: C:\Vault Working Folder\Heat Seal Vault\Products\Super Market\6501\6501-002.iam

**CONFIDENTIAL**  
 THIS PRINT IS PROPERTY OF, AND DISCLOSES PROPRIETARY INFORMATION OF HEAT SEAL. IT IS LOANED FOR REFERENCE ONLY, AND MAY NOT BE REPRODUCED OR FORWARDED ELECTRONICALLY IN ANY MANNER, OR ITS CONTENTS DISCLOSED TO OTHERS, WITHOUT THE EXPLICIT WRITTEN PERMISSION OF OWNER AND MUST BE DESTROYED UPON REQUEST.

INSTALL PIN & WIRE AFTER HANDLE ASM