

REVISION HISTORY				
REV	ECN #	DATE	BY	DESCRIPTION
0	2585	7/28/2010	TMM	INITIAL RELEASE
1	4207	3/8/2021	MG	REPLACE 1903-243 WITH 1903-085

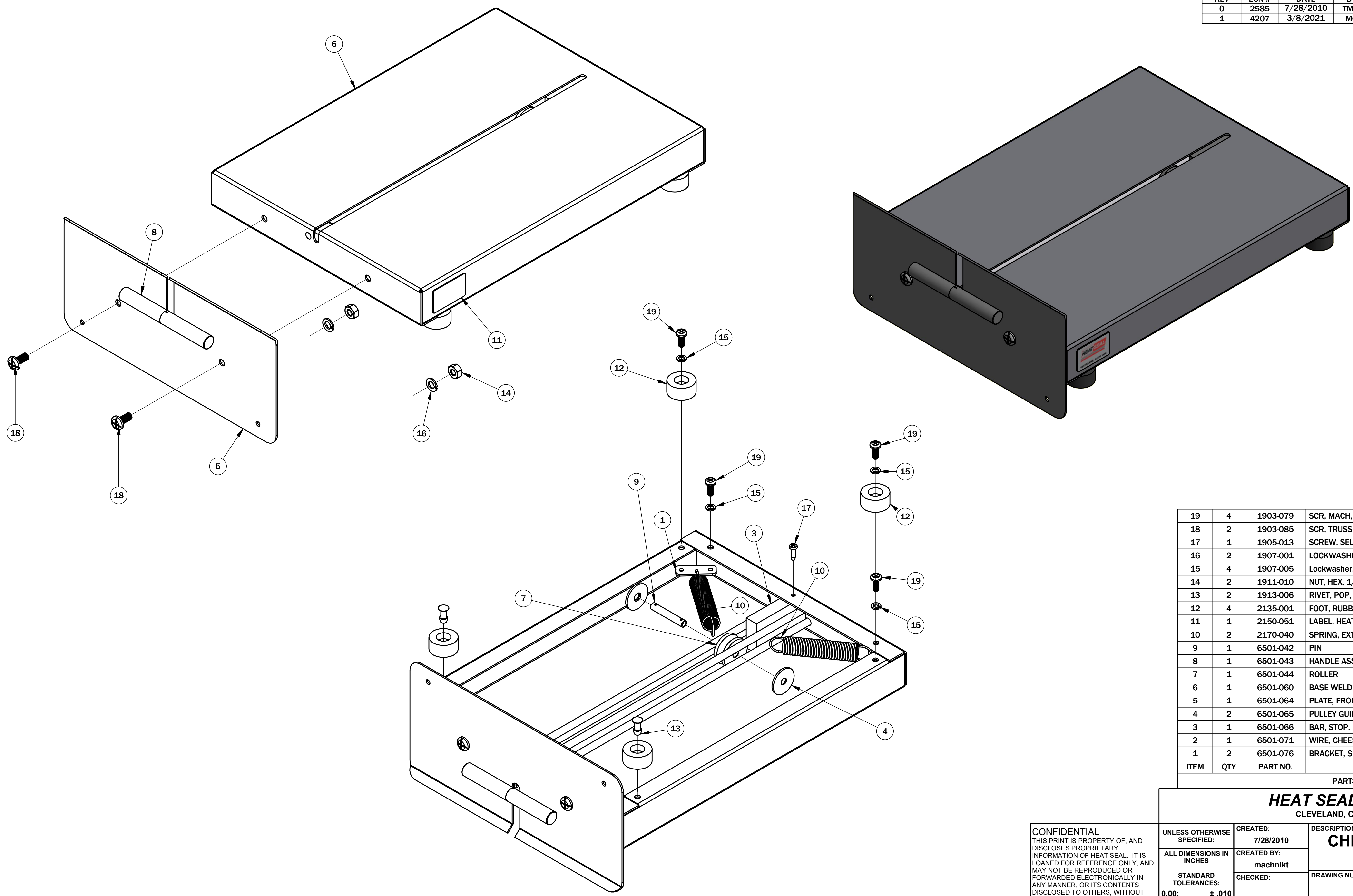

ITEM	QTY	PART NO.	DESCRIPTION
19	4	1903-079	SCR, MACH, PN HD, PHIL, SS, 10-32 x 1/2 LG
18	2	1903-085	SCR, TRUSS HD. SLOTTED, 1/4-20 X 1/2
17	1	1905-013	SCREW, SELF TAP, PAN HD, SS, 6-32 x 0.5 LG
16	2	1907-001	LOCKWASHER, SPLIT, 1/4 MED, SS
15	4	1907-005	Lockwasher, Split, #10 Med, SS
14	2	1911-010	NUT, HEX, 1/4-20 SS
13	2	1913-006	RIVET, POP, ALUM/ALUM, #66
12	4	2135-001	FOOT, RUBBER, 1" OD
11	1	2150-051	LABEL, HEAT SEAL LOGO 1-9/16 X 15/16
10	2	2170-040	SPRING, EXTENSION, SS
9	1	6501-042	PIN
8	1	6501-043	HANDLE ASSY
7	1	6501-044	ROLLER
6	1	6501-060	BASE WELD ASSY, CHEESE CUTTER
5	1	6501-064	PLATE, FRONT, CHEESE CUTTER
4	2	6501-065	PULLEY GUIDE RAIL SPACER
3	1	6501-066	BAR, STOP, PULLEY
2	1	6501-071	WIRE, CHEESE CUTTER, CC14
1	2	6501-076	BRACKET, SPRING, CC14

PARTS LIST

**HEAT SEAL/AMPAK**  
CLEVELAND, OHIO 44125

CONFIDENTIAL  
THIS PRINT IS PROPERTY OF, AND DISCLOSES PROPRIETARY INFORMATION OF HEAT SEAL. IT IS LOANED FOR REFERENCE ONLY, AND MAY NOT BE REPRODUCED OR FORWARDED ELECTRONICALLY IN ANY MANNER, OR ITS CONTENTS DISCLOSED TO OTHERS, WITHOUT THE EXPLICIT WRITTEN PERMISSION OF OWNER AND MUST BE DESTROYED UPON REQUEST.

UNLESS OTHERWISE SPECIFIED:  
ALL DIMENSIONS IN INCHES  
STANDARD TOLERANCES:  
0.00: ± .010  
0.000: ± .005  
ANGLE: ± 1'

CREATED: 7/28/2010  
CREATED BY: machnik  
CHECKED BY:  
DESCRIPTION:  
**CHEESE CUTTER, PULL TYPE**  
DRAWING NUMBER:  
**6501-003**  
REVISION:  
**1**  
SIZE: D SCALE: NONE SHEET: 1 OF: 1