

REVISION HISTORY				
REV	ECN	DATE	DONE BY	DESCRIPTION
1	3894	9/27/2018	NS	ADDED 2150-415
2	4407	3/16/2023	NS	ADDED 6520-100-15, 1909-016, 1907-005, & 1903-833

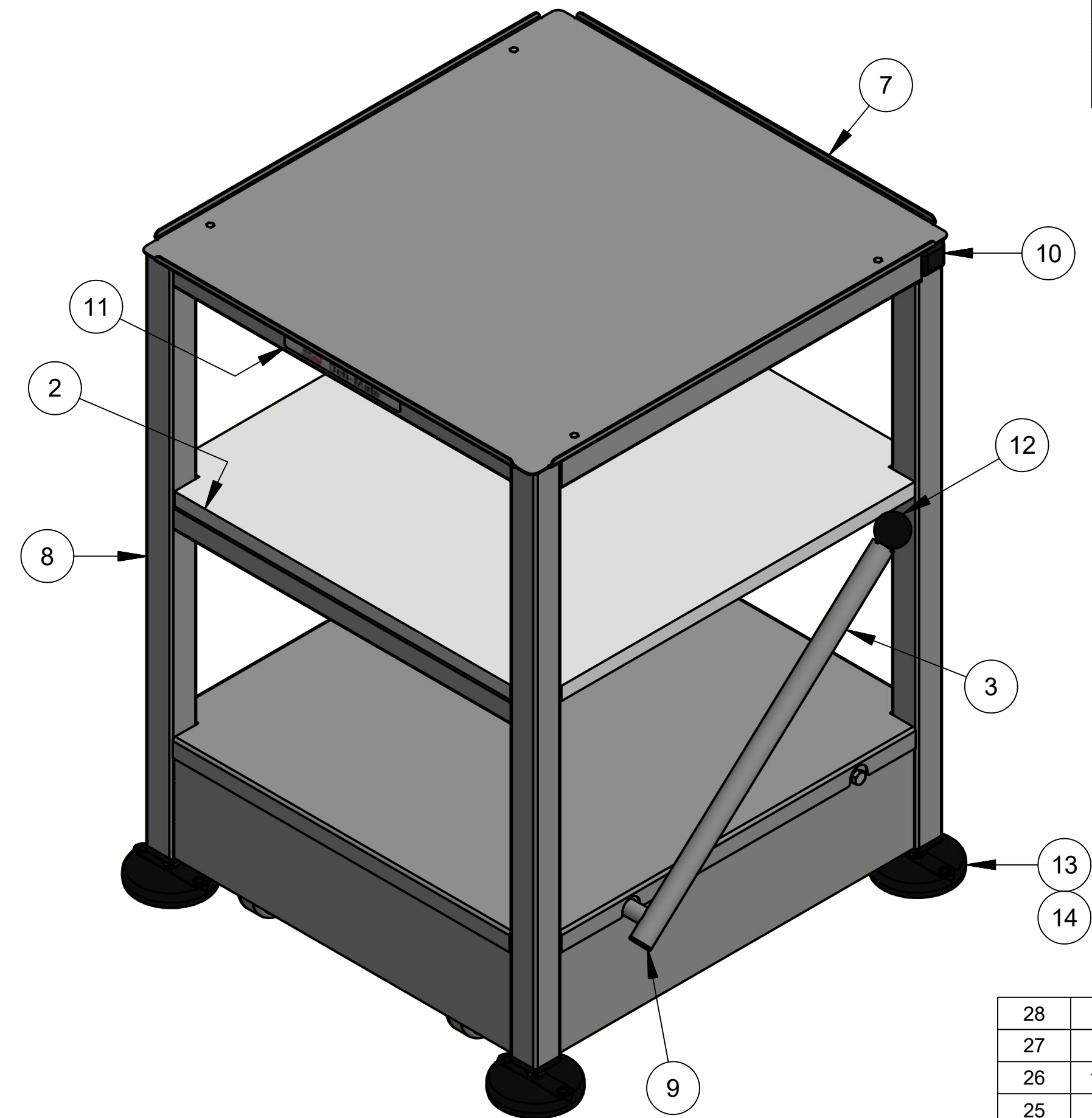

28	2	0910-038	BUMPER, 1" OD, 1/2" THK, 10-24 X 3/8 LG
27	1	1903-004	Screw, Cap, Hex Head 1/4-20 x 1-3/4
26	12	1903-180	SCR, CAP, HEX HD, SS, 1/4-20 X 2 LG, W/ 3/4 THD
25	4	1903-824	SCR, CAP, HEX HD, SS, 3/8-16 x 3.5" LG
24	4	1903-833	10-32 X 1-5/8" LG, SCR, CAP, BUTTON HD, SOC, SS
23	3	1903-838	SCR, HEX, SS, 3/8-16 X 3-1/4 LG
22	12	1907-001	LOCKWASHER, SPLIT, 1/4 MED, SS
21	4	1907-005	Lockwasher, Split, #10 Med, SS
20	24	1909-002	WASHER, FLAT, SS, 5/8 OD X 1/4 ID X .065 THK
19	4	1909-016	WASHER, FLAT, .204X.690, SS
18	12	1911-010	NUT, HEX, 1/4-20 SS
17	1	1911-021	NUT, HEX, NYLOCK 1/4-20, SS
16	7	1911-145	NUT, HEX, LOCK, SS, 3/8-16
15	4	2125-015	WHEEL, SWIVEL, NON-LOCKING
14	4	2135-043	INSERT, LEVELER, NYLON, 1.5" SQ, 3/6-16 THD
13	4	2135-044	LEVELER, 4" DIA NONSKID, 3/8-16 STEM
12	1	2145-059	KNOB, BALL, 1-1/2" DIA, 5/16-18 X 1/2 THD
11	1	2150-415	LABEL, DOMED, DELIMATE
10	2	2195-004	Plug, Cap, Black 1 1/4
9	1	2195-039	PLUG, HOLE, BLACK, 1" OD
8	1	6520-100	WELDMENT ASSEMBLY, DELIMATE
7	1	6520-100-15	SHELF, TOP, ASSEMBLY
6	1	6520-101	PLATFORM, LIFT
5	1	6520-102	WELDMENT, LINK, DRIVE
4	1	6520-103	WELDMENT, LINK, FOLLOWER
3	1	6520-104	WELDMENT, HANDLE
2	1	6520-105	SHELF, WHITE BOARD
1	1	7000-002	PACKAGE INSTRUCTION

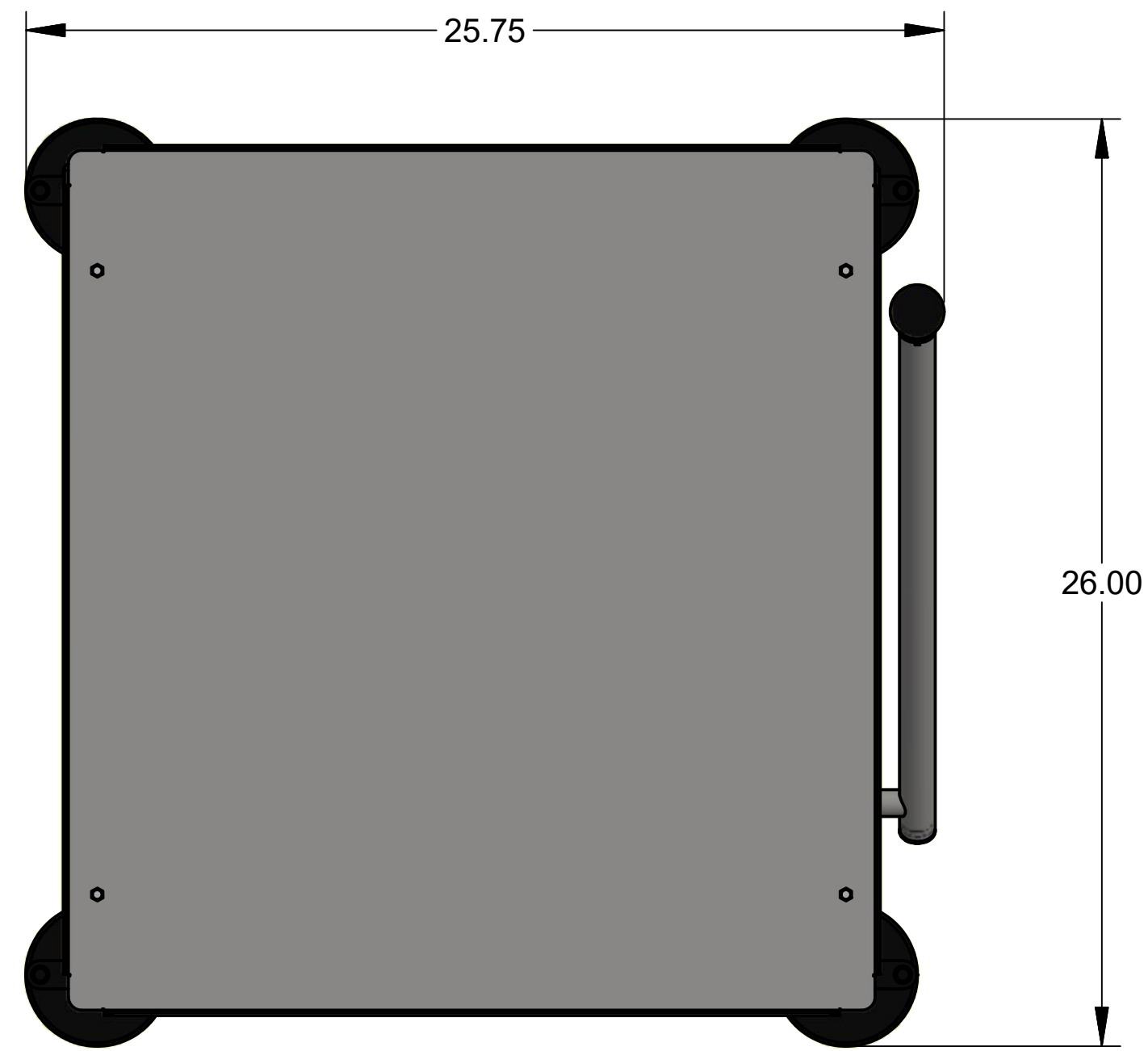
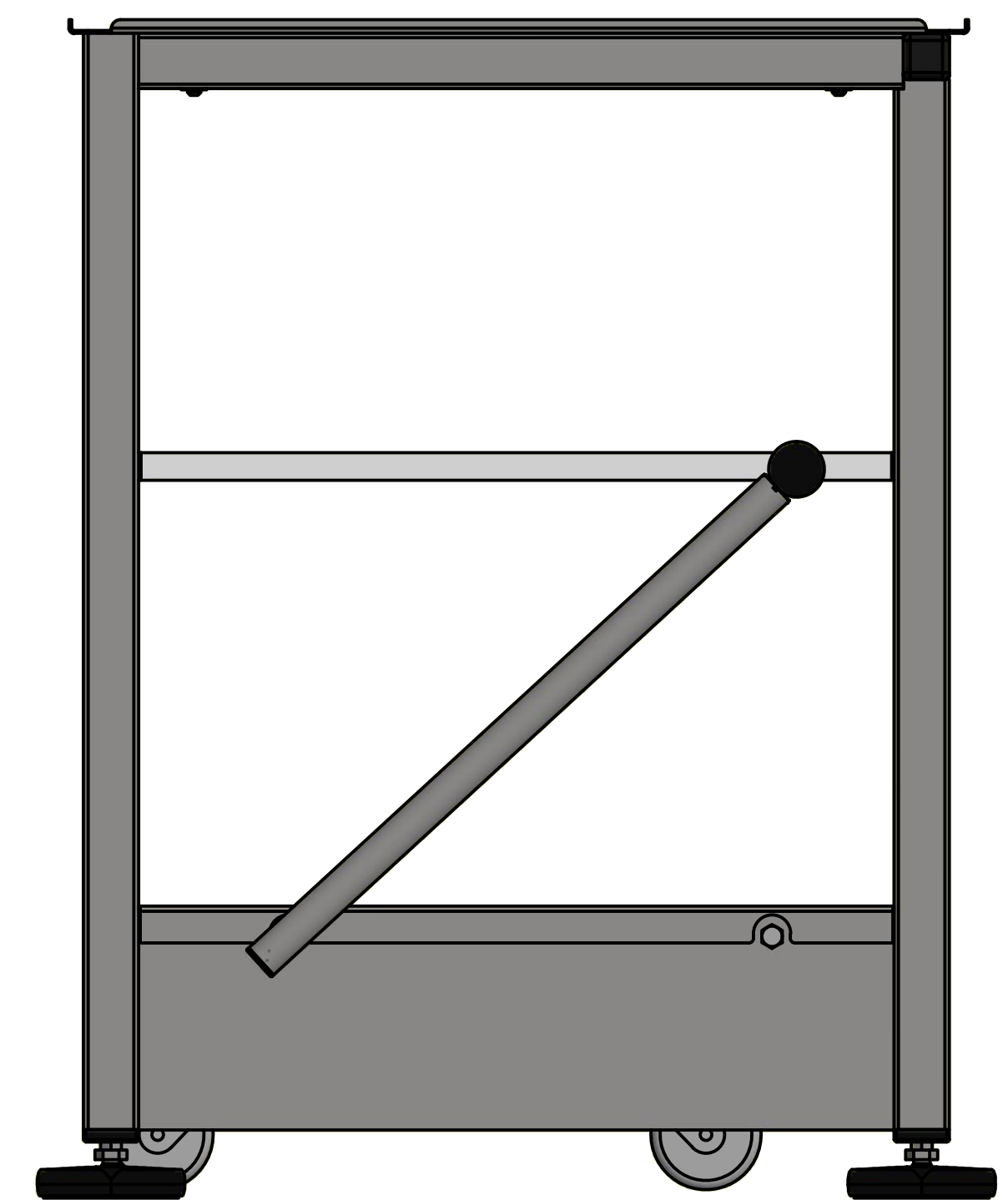
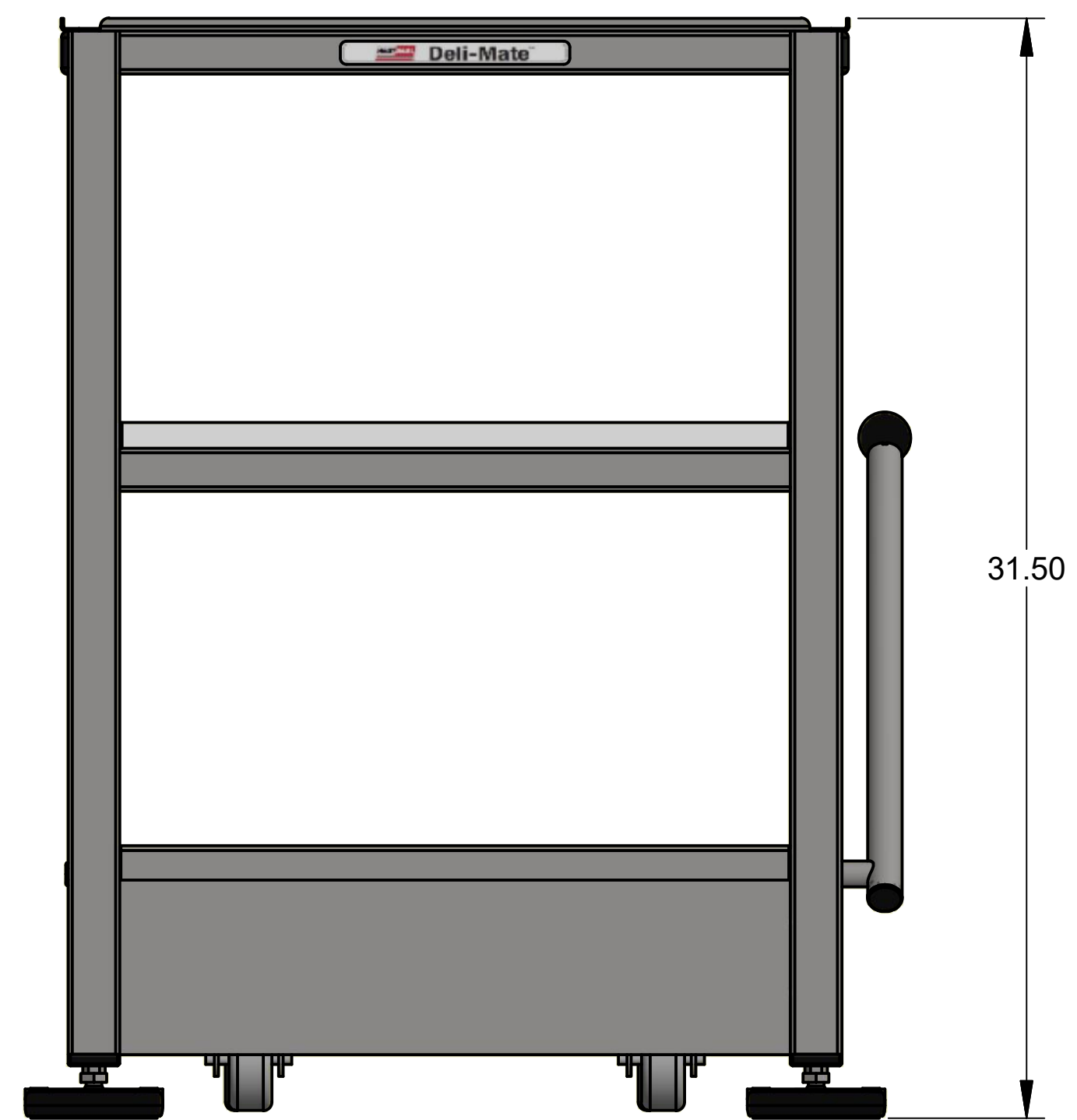

**Material Specification**  
**HEAT SEAL/AMPAK**  
 CLEVELAND, OHIO 44125

DESCRIPTION:  
**DELIMATE, SLICER STAND**

CONFIDENTIAL  
 THIS PRINT IS PROPERTY OF, AND DISCLOSES PROPRIETARY INFORMATION OF HEAT SEAL. IT IS LOANED FOR REFERENCE ONLY, AND MAY NOT BE REPRODUCED OR FORWARDED ELECTRONICALLY IN ANY MANNER, OR ITS CONTENTS DISCLOSED TO OTHERS, WITHOUT THE EXPLICIT WRITTEN PERMISSION OF OWNER AND MUST BE DESTROYED UPON REQUEST.

DRAWING NUMBER:  
**6520-000**

REVISION:  
**2**

SIZE: D SCALE: NONE SHEET: 1 OF: 2

**NOTE:**  
 FOLLOW PACKAGE INSTRUCTION 7000-002 BEFORE SHIPPING.

# WHEEL ASSEMBLY

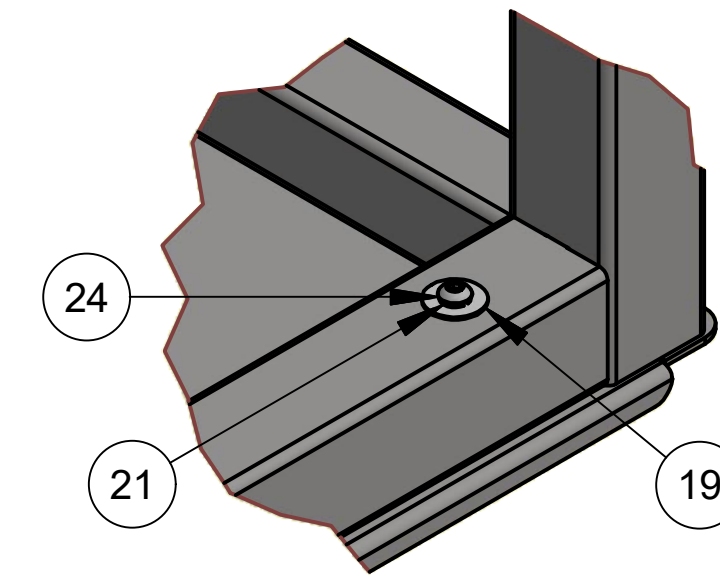
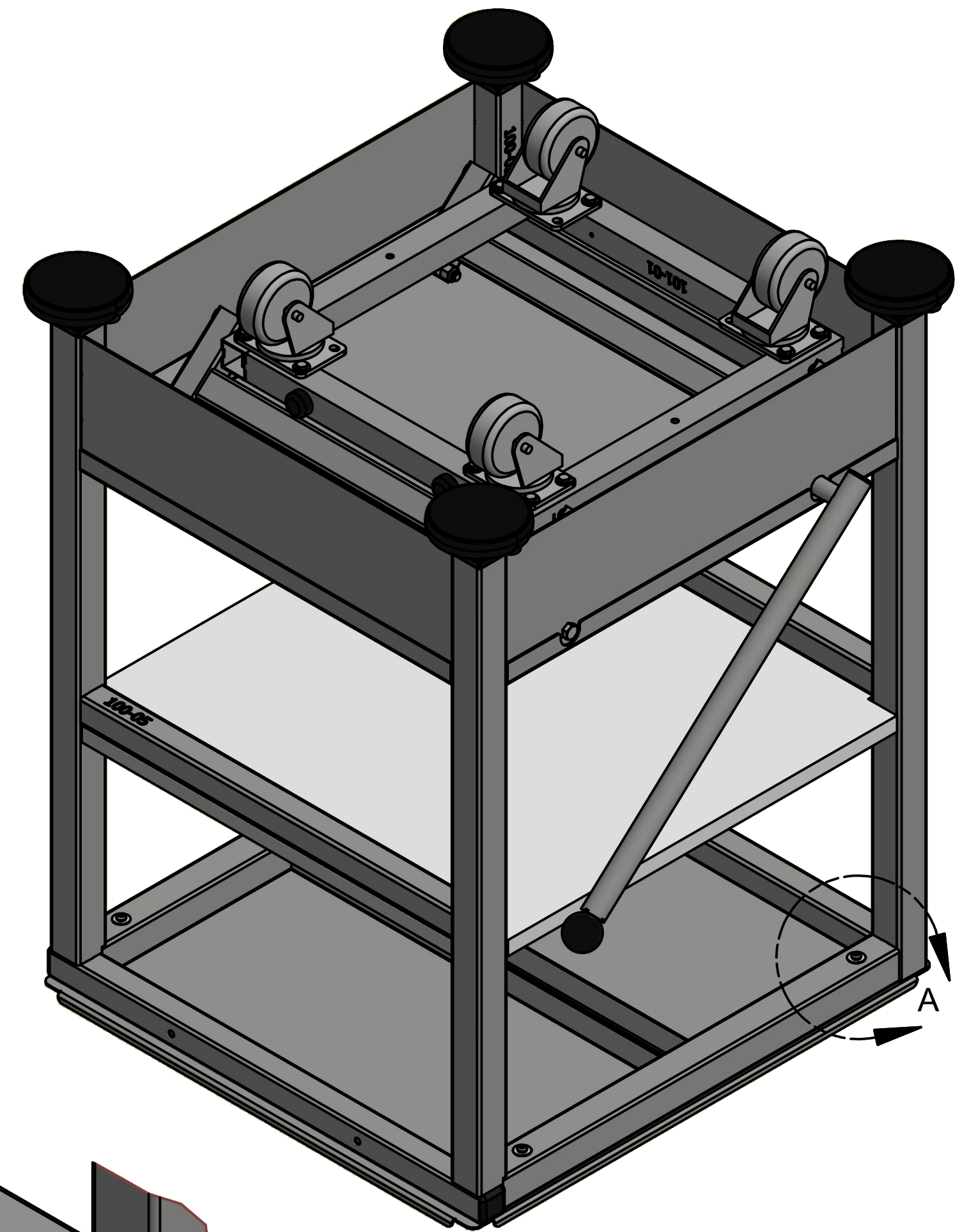
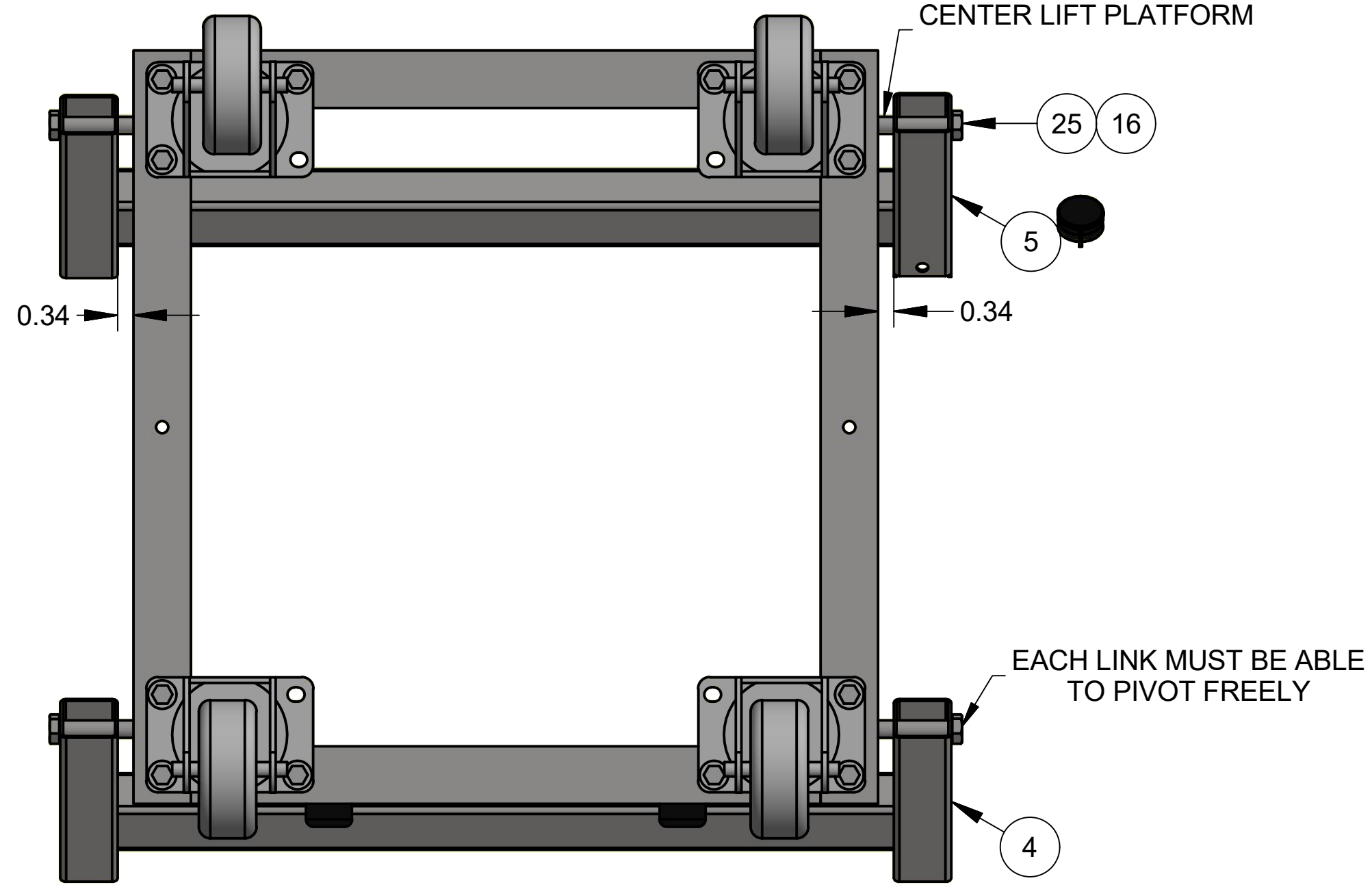
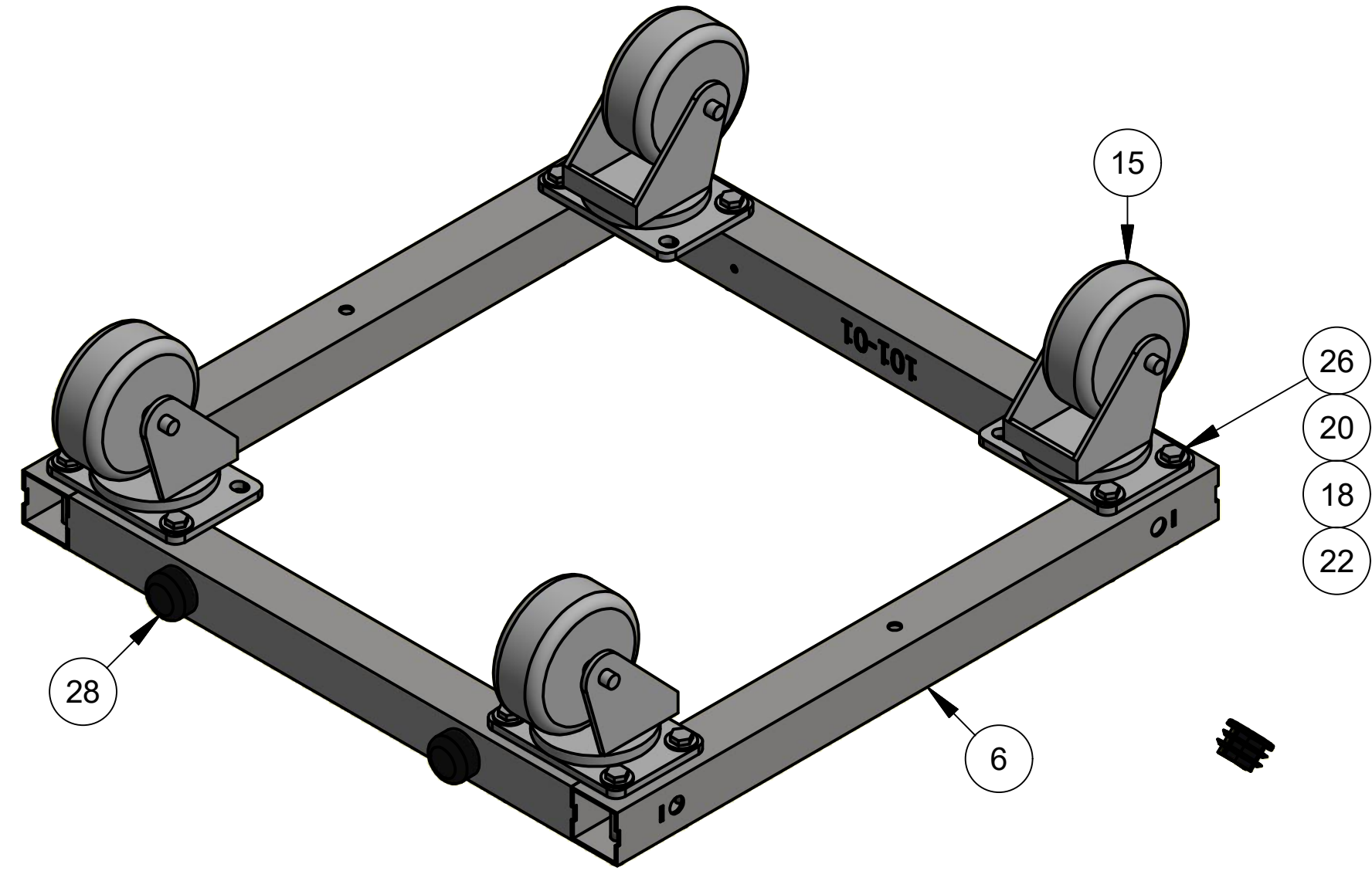

DETAIL A

**NOTE:**  
 USE MS100640 LOCTITE GENERAL PURPOSE ANTI-SEIZE COPPER LUBRICANT ON EACH STAINLESS STEEL FASTENER THAT USES A NYLOCK NUT.

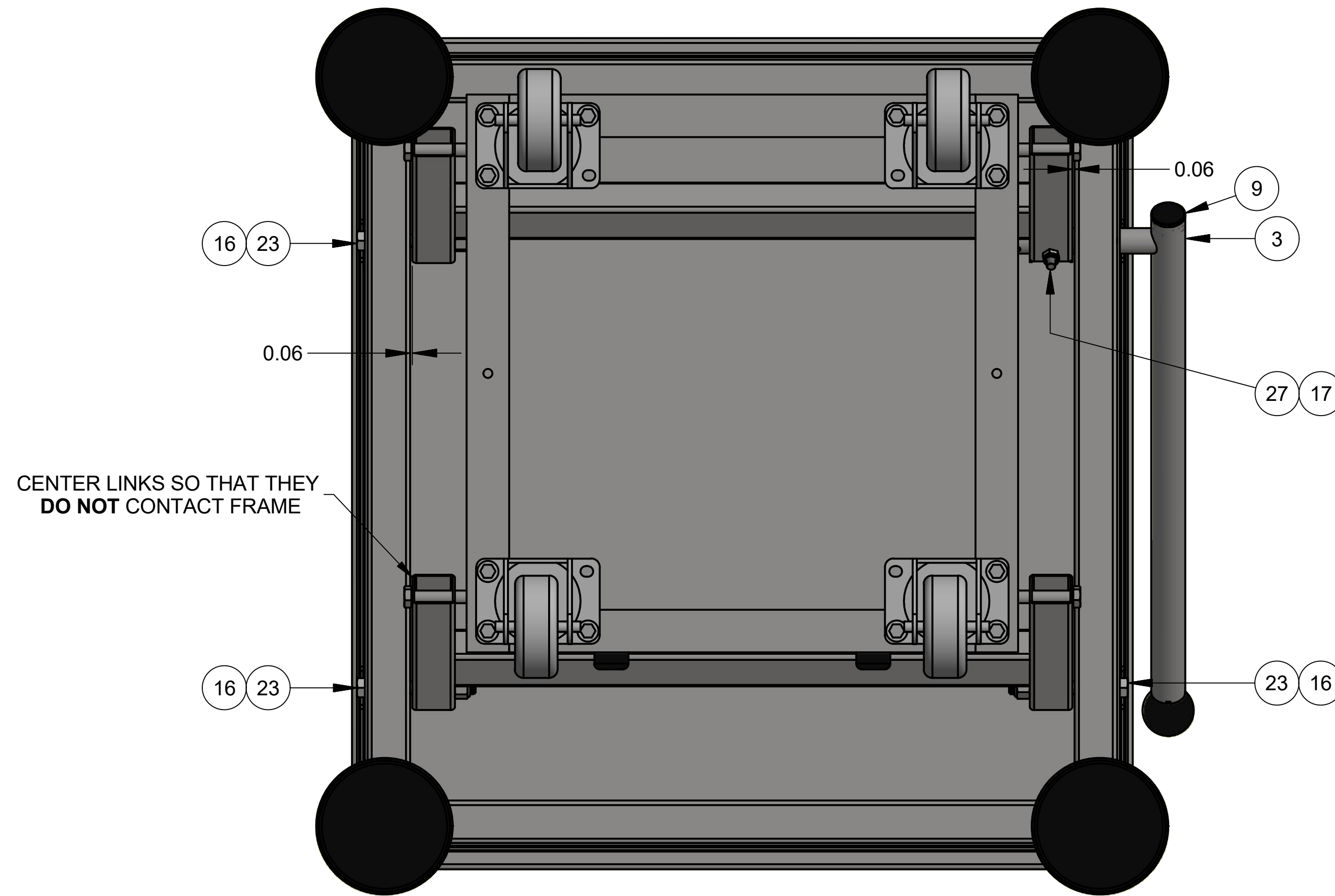

28	2	0910-038	BUMPER, 1" OD, 1/2" THK, 10-24 X 3/8 LG
27	1	1903-004	Screw, Cap, Hex Head 1/4-20 x 1-3/4
26	12	1903-180	SCR, CAP, HEX HD, SS, 1/4-20 X 2 LG, W/ 3/4 THD
25	4	1903-824	SCR, CAP, HEX HD, SS, 3/8-16 x 3.5" LG
24	4	1903-833	10-32 X 1-5/8" LG, SCR, CAP, BUTTON HD, SOC, SS
23	3	1903-838	SCR, HEX, SS, 3/8-16 X 3-1/4 LG
22	12	1907-001	LOCKWASHER, SPLIT, 1/4 MED, SS
21	4	1907-005	Lockwasher, Split, #10 Med, SS
20	24	1909-002	WASHER, FLAT, SS, 5/8 OD X 1/4 ID X .065 THK
19	4	1909-016	WASHER, FLAT, .204X.690, SS
18	12	1911-010	NUT, HEX, 1/4-20 SS
17	1	1911-021	NUT, HEX, NYLOCK 1/4-20, SS
16	7	1911-145	NUT, HEX, LOCK, SS, 3/8-16
15	4	2125-015	WHEEL, SWIVEL, NON-LOCKING
14	4	2135-043	INSERT, LEVELER, NYLON, 1.5" SQ, 3/16 THD
13	4	2135-044	LEVELER, 4" DIA NONSKID, 3/8-16 STEM
12	1	2145-059	KNOB, BALL, 1-1/2" DIA, 5/16-18 X 1/2 THD
11	1	2150-415	LABEL, DOMED, DELIMATE
10	2	2195-004	Plug, Cap, Black 1 1/4
9	1	2195-039	PLUG, HOLE, BLACK, 1" OD
8	1	6520-100	WELDMENT ASSEMBLY, DELIMATE
7	1	6520-100-15	SHELF, TOP, ASSEMBLY
6	1	6520-101	PLATFORM, LIFT
5	1	6520-102	WELDMENT, LINK, DRIVE
4	1	6520-103	WELDMENT, LINK, FOLLOWER
3	1	6520-104	WELDMENT, HANDLE
2	1	6520-105	SHELF, WHITE BOARD
1	1	7000-002	PACKAGE INSTRUCTION
ITEM	QTY	PART NUMBER	DESCRIPTION

Material Specification

**CONFIDENTIAL**  
 THIS PRINT IS PROPERTY OF, AND DISCLOSES PROPRIETARY INFORMATION OF HEAT SEAL. IT IS LOANED FOR REFERENCE ONLY, AND MAY NOT BE REPRODUCED OR FORWARDED ELECTRONICALLY IN ANY MANNER, OR ITS CONTENTS DISCLOSED TO OTHERS, WITHOUT THE EXPLICIT WRITTEN PERMISSION OF OWNER AND MUST BE DESTROYED UPON REQUEST.

UNLESS OTHERWISE SPECIFIED:  
 ALL DIMENSIONS IN INCHES  
 STANDARD TOLERANCES:  
 0.00: ± .010  
 0.000: ± .005  
 ANGLE: ± 1'

**HEAT SEAL/AMPAK**  
 CLEVELAND, OHIO 44125

DESCRIPTION:  
**DELIMATE, SLICER STAND**

DRAWING NUMBER:  
**6520-000**

REVISION:  
**2**

SIZE: D SCALE: NONE SHEET: 2 OF: 2