

ANY SERVICE DESCRIBED MUST BE PERFORMED BY A QUALIFIED SERVICE TECHNICIAN.

- **Replacement Wire Part Numbers** CC-12: 6501-010 (5 per pkg.); CC-20: 6501-011 (5 per pkg.)

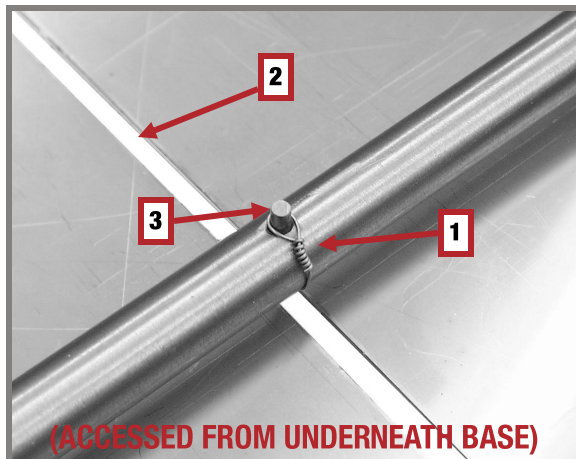

- Wire has one large loop and one small loop on the ends. Pass the wire end with the small loop (1) through the slot in the base (2), then over stud (3).

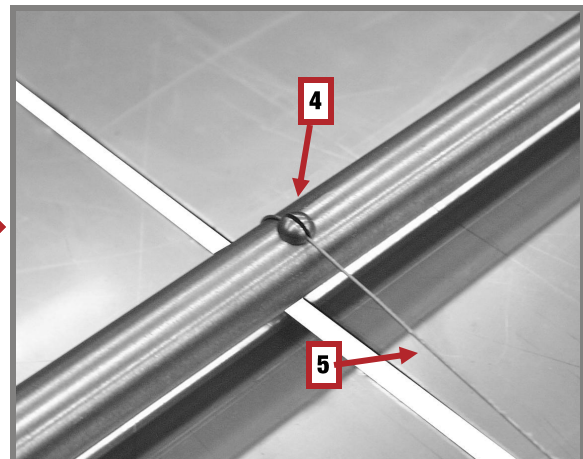

- Then turn arm to reveal slotted head (4) and thread wire (5) through the slot to guide wire

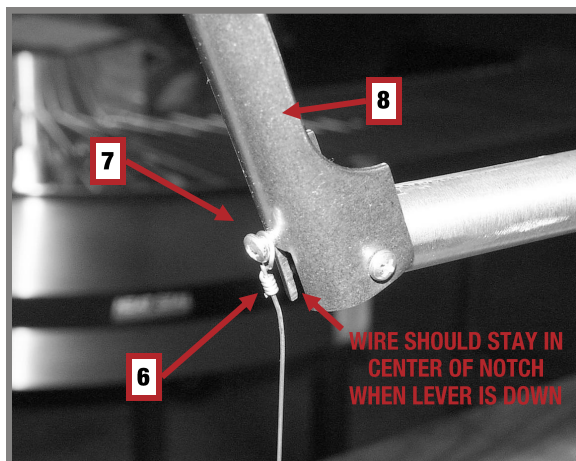

- Then place the large loop (6) over the anchor screw (7) on the flip lever (8) on the handle.

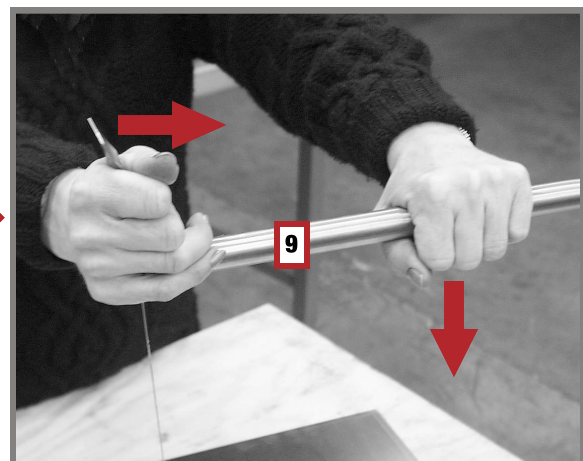

- While flipping the lever into place, pressure must be exerted on the cutter arm (9) to allow the wire to be tightened securely. Force lever over slowly to tension wire. Check that wire stays centered in the slot on the flip lever.



CHEESE CUTTER APPLICATIONS



- Cheese cutter with cheese stop and movable arm



- Cheese cutter with table stop and stationary arm

FOR FURTHER ASSISTANCE,
CONTACT YOUR DISTRIBUTOR OR CALL HEAT SEAL