

OPERATING & SERVICE PARTS MANUAL
MASTER & SHIPMATE SKIN PACKAGING MACHINES
FOR MODELS: SHIPMATE SP1824, AND MASTER MODELS FROM MP2430 TO MP3672



TABLE OF CONTENTS



Safety Precautions	3
Shipping Damage//Returns.....	4
Warranty Information	5
Installation of Master.....	6
Machine Specifications	7
Sequence of Operations for Skin Cycle.....	8
Operator Control Functions.....	9
Touchscreen Controls.....	10
Maintenance & Repair Instructions.....	25
Replacing the Cutoff Wire.....	26
Features of a Master Skin Machine	29
Ordering Parts	30
Troubleshooting	33
Spirad Service & Parts	35
Spirad Inspection & Replacement.....	36
Pneumatic Assembly SP-MP2430	39
Pneumatic Assembly MP3036-3654	41
Infrared Sensor Assembly	43
Notes	44

SAFETY PRECAUTIONS AND WARNINGS



ANY UNAUTHORIZED MODIFICATIONS TO THIS MACHINE MAY CAUSE DAMAGE AND/OR PERSONAL INJURY AND WILL VOID THE AMPAK PRODUCT WARRANTY. PLEASE OBSERVE ALL PRECAUTIONARY STATEMENTS.

- DO NOT OPERATE THIS MACHINE WITHOUT READING THIS INSTRUCTION MANUAL FIRST.
- BE SURE THE MACHINE IS CONNECTED TO THE BUILDING ELECTRICAL SAFETY GROUND.
- BE SURE POWER IS OFF OR DISCONNECTED FROM THE MAIN DISCONNECT BEFORE PERFORMING MAINTENANCE OR SERVICE OF THE MACHINE
- DO NOT OPERATE THE MACHINE WITHOUT GUARDS IN PLACE.
- DO NOT OPERATE THE MACHINE IN A MANNER FOR WHICH IT WAS NOT INTENDED TO BE USED.
- DO NOT TOUCH HEATED SURFACES.

Some drawings included with this manual are shown with covers off for clarity purposes only. All guards must be in place before operating this machine.

Failure to replace, repair or report missing, defective or modified safety guards may result in injury to you or your fellow workers. ALWAYS REPORT UNSAFE CONDITIONS TO YOUR SUPERVISOR OR PLANT MANAGER.

Your attention is directed to the Ampak parts and service warranty which accompanies all new Ampak equipment. The terms and conditions of this warranty apply to non-modified machines. Any unauthorized modifications will void the warranty.



SHIPPING DAMAGE CLAIMS

Upon arrival of your new machine, inspect the crate for any visible damage to the crate. Then uncrate and/or unpack the machine and inspect it for visible damage or missing parts. If any damage is found, it is your responsibility to contact the carrier and immediately file a claim with the carrier. Also record your serial number so that in case you need something warranted it is available to reference.

Ampak is not responsible for any damages to the machine once it leaves our facility shipping dock in Cleveland, Ohio.

RETURN PROCEDURE

To return warrantable parts, follow the below procedure:

Have your service technician examine the application, the machine and the parts to determine if they can be covered by the warranty.

Next, have the technician call Ampak customer service (see back cover) and request a Return Authorization Number (RA#).

Then place an order for the replacement part or parts. On the order refer to the RA number, model and serial numbers of the machine (located on the side of the machine or printed on this manual).

Return the defective part or parts prepaid to Ampak.

Ampak engineering department will examine the returned items and customer service will issue a credit should the part or parts be defective.

WARRANTY INFORMATION



AMPAK WARRANTY

For a period of one year after the shipment of PRODUCT from the factory, Ampak will supply free of charge, FOB Cleveland, Ohio, replacement parts for parts that prove defective in workmanship or material. Defective parts must be returned, freight prepaid to Ampak for full credit. The warranty does not extend to parts designed to wear in normal operation and must be replaced periodically, or where damage is caused by negligence, accident, abuse or improper installation and operation.

GOODS NOT MANUFACTURED BY AMPAK CARRY ONLY THE MANUFACTURER'S WARRANTY.

Ampak assumes no responsibility for the quality and performance of films, board or any other materials used with the Ampak product.

THIS UNDERTAKING IS IN LIEU OF ALL OTHER WARRANTIES, EXPRESSED OR IMPLIED, INCLUDING MERCHANTABILITY AND FITNESS FOR PARTICULAR PURPOSES.

LIMITATION OF LIABILITY

BUYER AGREES THAT IN NO EVENT SHALL AMPAK HAVE LIABILITY FOR DIRECT DAMAGES IN EXCESS OF THE CONTRACT PRICE OF THE GOODS IN RESPECT OF WHICH CLAIM IS MADE AND BUYER FURTHER AGREES THAT IN NO EVENT SHALL AMPAK FOR ANY CLAIM OF ANY KIND OF LIABILITY FOR LOSS OF USE, LOSS OF PROFITS OR FOR ANY INDIRECT, INCIDENTAL OR CONSEQUENTIAL DAMAGES.

CANCELLATION

Buyer may cancel order only by providing written notice received at our office prior to shipment. Deposits are non-refundable.

Heat Seal will stop work on the order promptly once written notice has been received Standard Equipment: Buyer agrees to pay all Heat Seal's REASONABLE COSTS due to order cancellation Special or Non-Standard Equipment: Heat Seal retains non-refundable deposit. Buyer agrees to pay all additional costs incurred by Heat Seal in excess of non-refundable deposit.

TITLE RISK OF LOSS INSURANCE ASSIGNMENT

Delivery of goods FOB Ampak's plant to a carrier or Buyer shall constitute transfer of risk of loss. Title to the goods shall remain with Ampak until the full purchase price is paid. Buyer agrees to keep the goods fully insured with Ampak as a named loss payee until the full purchase price is paid. Neither Buyer nor Ampak shall assign this contract without prior written consent to the other.

THIS WARRANTY WILL BE VOIDED IF THE EQUIPMENT IS NOT INSTALLED BY AN AUTHORIZED AMPAK DISTRIBUTOR SERVICE TECHNICIAN. THE PURCHASER IS SOLELY RESPONSIBLE FOR THE SAFE INSTALLATION AND OPERATION OF THE MACHINE. DAMAGE CAUSED BY MISUSE, MISAPPLICATION OR MODIFICATION WILL NOT BE COVERED BY THIS WARRANTY.

Revised 11/22

INSTALLATION



- Make sure that the electrical and pneumatic supplies are adequate for the model you received. Current requirements are listed on the machine nameplate and are full load maximum for this machine.
- Installation should be performed by factory trained personnel or qualified electricians to ensure compliance with local, state and federal safety codes.
- The machine should rest on a hard, flat surface. Leveling of the platen can be accomplished by adjusting the feet of the machine.
- Do not install the machine in aisles or walkways. Provide adequate space around the machine to allow operators and service personnel plenty of room.
- Avoid installing your machine under or near fans, vents or open doorways and windows to prevent circulating air from distorting the oven heat pattern. Noticeably poor packaging will result from too much circulating air.
- Raise or lower the oven to provide ample clearance for your tallest product and/or ease of loading products for the operator.
- Do not switch on the machine disconnect or circuit breaker until voltage is confirmed correct with a voltmeter. Machine warranty does not cover damage caused by unauthorized use or personnel.
- Prior to applying power to the machine, inspect all electrical connections for looseness that may have occurred during shipment. Tighten any bolts and fasteners that may have worked loose during transit.

SPECIAL NOTE: National Electrical Code and most local electrical codes require that the machine frame be connected to the earth via plant service ground conductors. Earth grounding prevents personnel from being exposed to lethal voltage in the case of a short circuit. A connection point is provided on the electrical panel.

MACHINE SPECIFICATIONS



MACHINE SPECIFICATIONS

Please refer to machine nameplate for correct air and electrical requirements.

FILM & BOARD

Film: (3-20 Mil) Polyethylene, Surlyn, Co-Polymers, PETG, Primacor, PVC. Recommend electrostatic treatment to bonding surface.

Roll Width: 2" more than Platen width. For example, the shipmate 1824 has a 18" wide platen and requires 20" wide film. (20"), Roll O.D.: 9", I.D.: 3"

Board: Corrugated, all flutes and strengths - Shipmate cartons. Box board and SBS board for display packaging. Recommend coating bonding surface compatible with film.



Revised 11/22

SKIN PACKAGING CYCLE

- Connect electrical and air supply.
 - The orange “Power” light on the front door will illuminate to show the machine is powered up.
 - Turn the power switch to “ON”. This will energize the machine control circuit and power up the machine. When the touchscreen has come on the machine is ready to cycle.
 - If present; the automatic film frame will open and the platen will raise when the machine is connected to the plant compressed air supply.
 - Touch “RUN MACHINE” on the touchscreen to access the *HOME SCREEN*.
- Thread the film under the roller and between the upper and lower film frame. Adjust the position of the film roll so that it is in line with the frame and the film isn't biased to the front or rear.
 - For first time operation, the machine settings will need to be adjusted. See *Operator Control Functions* sections for setup instructions. When the settings have been set, press the “CYCLE START” button on the main screen to begin a cycle.
 - The automatic film frame will begin to close, the hot wire cutoff will energize, and the film frame will begin to rise to the upper position.
- When the film frame has reached its up position, load the card and product onto the vacuum plate or Infeed table if equipped.
 - If the Pre-heat portion of the cycle is turned on, the spirads will begin pulsing on and off to warm the film and prepare it for the heating portion of the cycle. The duration of the Pre-heat will last for a period of 3 minutes before timing out.
- Touch the “CYCLE START” button again to start the heat film portion of the cycle.
 - The oven energizes and heats the film. If the TEMP MODE option is selected, the FILM HEATED CYCLE duration will be based upon the temperature of the film (this is sensed by the small temperature sensor mounted to the side of the support holding the oven). If the TIME MODE option is selected, the machine will use a TIMED heat cycle. The duration of the heat cycle is then based on the time setting on the touchscreen HEAT FILM TIME setting.
 - When FILM HEATED CYCLE is complete, the HEAT PACKAGE and VACUUM CYCLE will begin. The vacuum turbines will come on and the film frame will lower.
 - When the film frame reaches its lower position, the heated film will be vacuumed down over the product and the card. When the HEAT PACKAGE TIME CYCLE has finished, the oven will shut off while the vacuum continues until the vacuum on time setting has been reached.
 - After the VACUUM ON TIME CYCLE has ended, the turbines will shut off, and the film frame will open.
 - If equipped with EZ-OUTFEED, The gripper arm will lower and extend into the seal area. The grippers will close on the card and pull the product card out of the seal area. Once clear of the frame, the frame closes, cuts the film and rises up once again. The Gripper will finish pulling the card onto the conveyor. The conveyor will drop and product will roll to end of conveyor.



SKIN PACKAGING CYCLE

- If not equipped with EZ-OUTFEED, Remove the skinned products and card through the open end of the frame. Touch the CYCLE START button to cut the film and raise the film frame. To ensure a clean cut of the film; move the completed card back towards the frame to create slack in the film. Too much film tension will prevent the film frame from closing fully. Now is the time to load another card onto the platen and start another cycle.

ACTUATION OF THE EMERGENCY STOP BUTTON DISCONNECTS THE CONTROL POWER ONLY. IT DOES NOT REMOVE HIGH VOLTAGE FROM THE HIGH CURRENT DEVICES IN THE CONTROL CABINET. THE DOOR MUST BE CLOSED BEFORE OPERATING THE MACHINE.

THE MACHINE CAN ONLY BE CONSIDERED SAFE TO WORK INSIDE OF WHEN THE POWER TO THE MACHINE HAS BEEN TURNED OFF.

OPERATOR CONTROL FUNCTIONS



TOUCHSCREEN OPERATION

- Plug machine into power source and turn on main disconnect switch, orange POWER ON light (1) on control panel illuminates.
- Turn ON/OFF Switch to ON position and touchscreen (2) illuminates.
- Touch RUN MACHINE (3) to advance to the main operating screens. The next screens contain adjustable machine parameters. The screens and parameter explanations are detailed on the next pages.

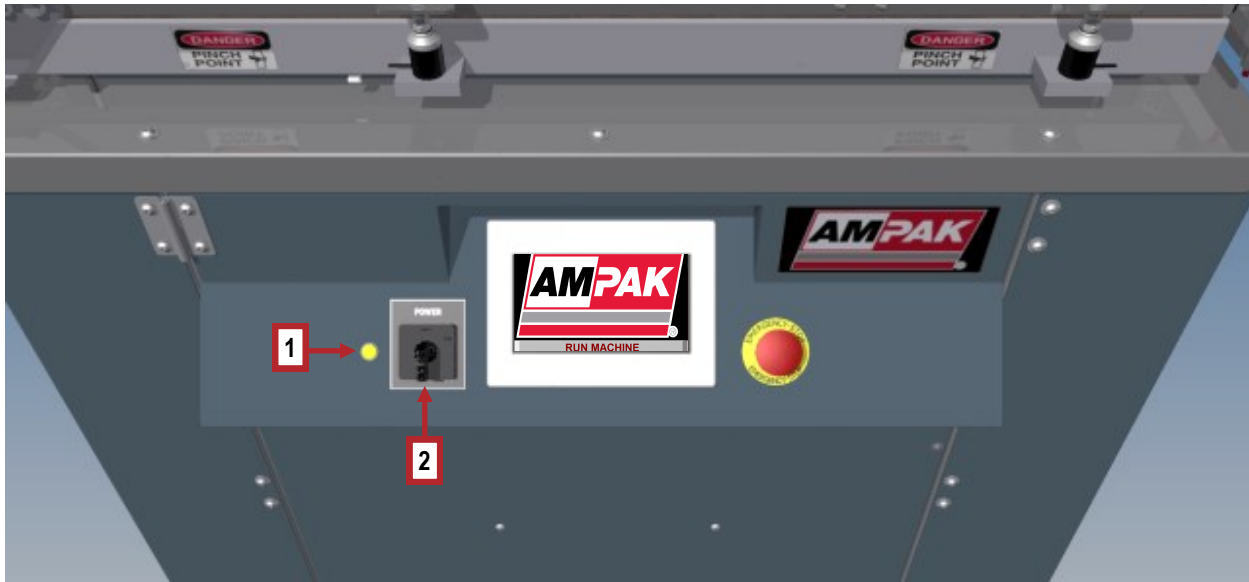

HMI SCREENS

The screen below is what will be seen on startup. Pressing the “Run Machine” button will take the operator to the *HOME* screen.



The HOME screen allows the operator to navigate to any screen. It is the main navigation screen of the touch display and is the only screen that allows the operator access the LOG IN pop-up window. This screen, as well as every other screen is equipped with the orange "Alarm Reset" button that allows the operator to clear alarm messages. A resettable cycle counter is also included at the bottom of the screen. The Master Cycle Counter tracks the amount of cycles the machine has ran over its lifetime.

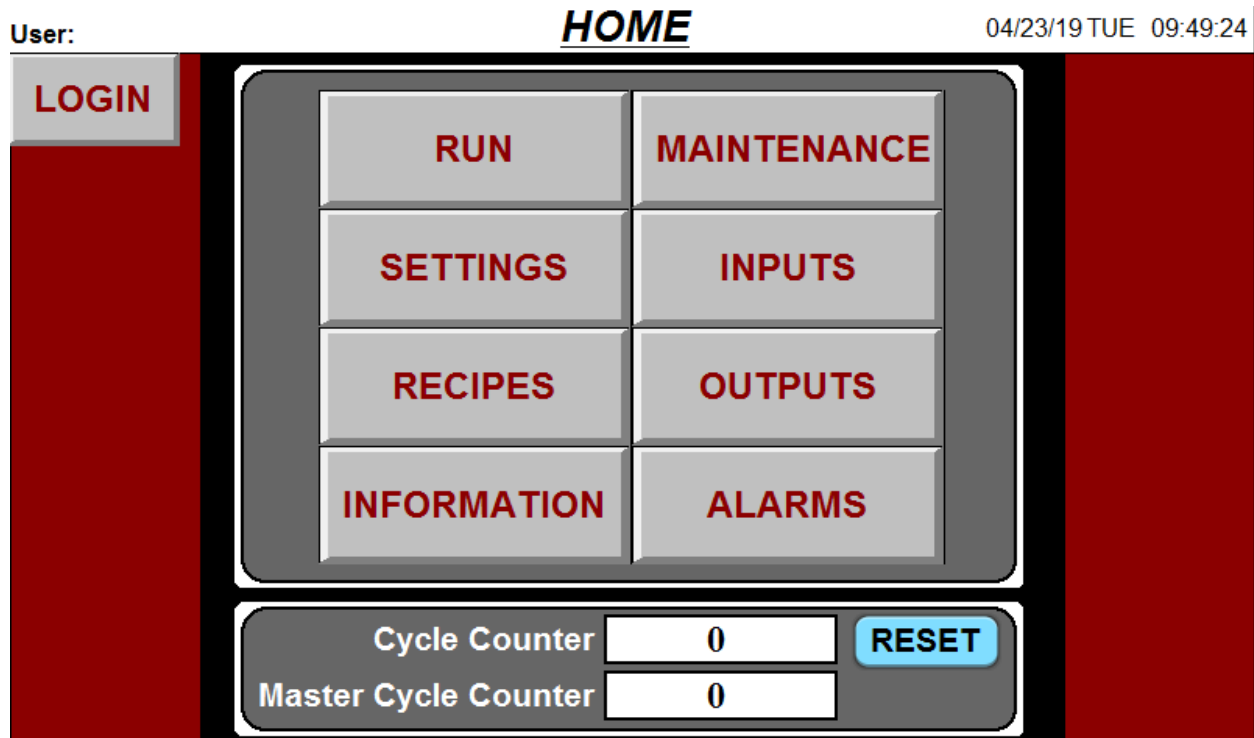

The MAIN screen is where the operator can watch the cycle progress from start to finish. The white textbox will display the current status of the machine. The timed portions of the cycle, Heat Film Time, Heat Package Time, and Vacuum On Time are all shown below and will count down from the time set in the settings screen. When equipped with a temperature sensor, the Film Temp box will appear and will display the current value read by the temperature sensor. The currently selected recipe is also displayed at the bottom of the screen.

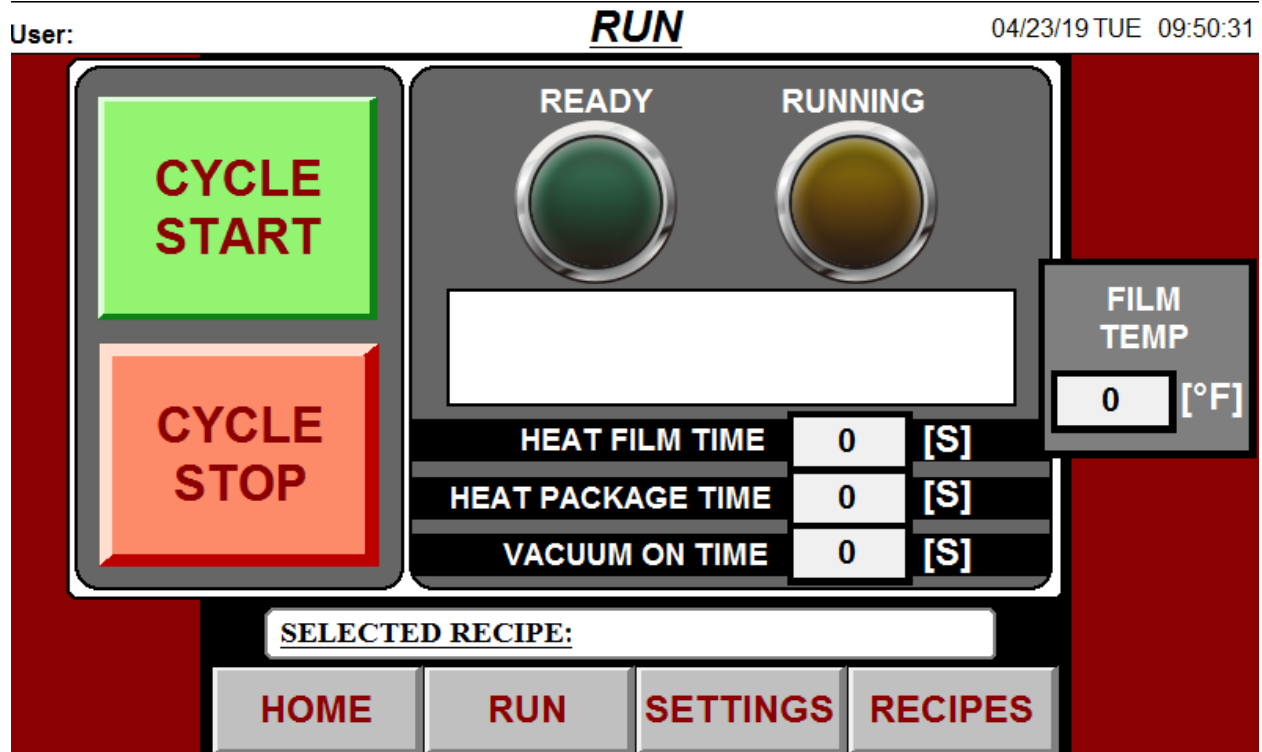

The SETTINGS screen allows the operator the ability to make changes to multiple different parameters. Each parameter can be incremented or decremented using the green up/down arrows or by clicking the parameter and typing in the desired value. You may also choose between time/temperature mode as well as decide whether to include Pre-heat portion of the cycle or not.

Vacuum Profile - (Restricted to Maint Only)

Default: No Profile

Description: This drop down box allows the user to select between (4) different options.

No Profile – When this option is selected, the vacuum turbine will run at the vacuum set point (adjustable from the settings screen).

Low to Medium – During the vacuum portion of the cycle, the vacuum turbine run at a low speed the first half of the vacuum cycle and at a medium speed during the second half of the cycle. The low and medium speed is hard-coded and cannot be changed with the “Vacuum Setpoint” parameter.

Low to High - During the vacuum portion of the cycle, the vacuum turbine run at a low speed the first half of the vacuum cycle and at a high speed during the second half of the cycle. The low and high speed is hard-coded and cannot be changed with the “Vacuum Setpoint” parameter.

Medium to High - During the vacuum portion of the cycle, the vacuum turbine run at a medium speed the first half of the vacuum cycle and at a high speed during the second half of the cycle. The medium and high speed is hard-coded and cannot be changed with the “Vacuum Setpoint” parameter.

Vacuum Set point [%] - (Restricted to Maint Only)

Default: 75

Description: This is the speed the vacuum turbine will run at when the vacuum profile is set to “No Profile”, e.g. a value of 75 would mean the turbine will run at 75% of maximum speed.

Range: 35 to 100

Vacuum On Time [S] - (Restricted to Maint Only)

Default: 30

Description: The value entered here will determine how long the vacuum turbine will run for in seconds.

Range: 0 to 60



Pre-Heat Duty Cycle - (Restricted to Maint Only)

Default: 0

Description: This value controls the way the pre-heat portion of the cycle performs. The lower the value, the slower the elements will pulse on/off. The higher the value, elements will pulse on/off faster.

Range: 0 to 10

Up Delay [S] - (Restricted to Maint Only)

Default: 3

Description: This value, in seconds, determines how long the film frame will wait before raising.

Range: 0 to 5

Hot Wire On Time [S] - (Restricted to Maint Only)

Default: 0.4 – 0.5 (Depends on film type/thickness.)

Description: This is the amount of time that the hot wire that cuts the film will turn on for.

Range: 0 to 1.5

Heat Film Time [S]

Default: Varies (Depends on film type/thickness.)

Description: This value determines how long the film will be heated for while the film frame is raised.

Range: 0 to 90

Temperature [°F] - (Restricted to Maint Only)

Default: 175

Description: This parameter is only used when “Temp” is selected on the MAIN screen. This value is the target set point for the temperature of the film.

Range: 0 to 200

Heat Package Time [S] - (Restricted to Maint Only)

Default: 10

Description: This value determines how long the film will be heated for while the film frame is lowered.

Range: 0 to 30

Cool Platen Timeout [S] - (Restricted to Maint Only)

Default: 0

Description: This value determines how long the vacuum turbine will turn on after the film is raised but before heat package portion of the cycle is started.

Range: 0 to 10

Machine Option Selection - (Restricted to Maint Only)

Default: Standard

Description: Allows the operator to select the machine configuration to be run depending on what features the machine does/does not have.

WARNING: The appropriate selection must be made to match the style of machine the user has. Choosing the "Infeed/Outfeed" option when not actually present, choosing "standard" when the machine is equipped with Infeed and/or Outfeed or any combination that does not match options the machine is physically equipped with can/will cause machine malfunction, damage to machine, damage to product, and/or operation injury

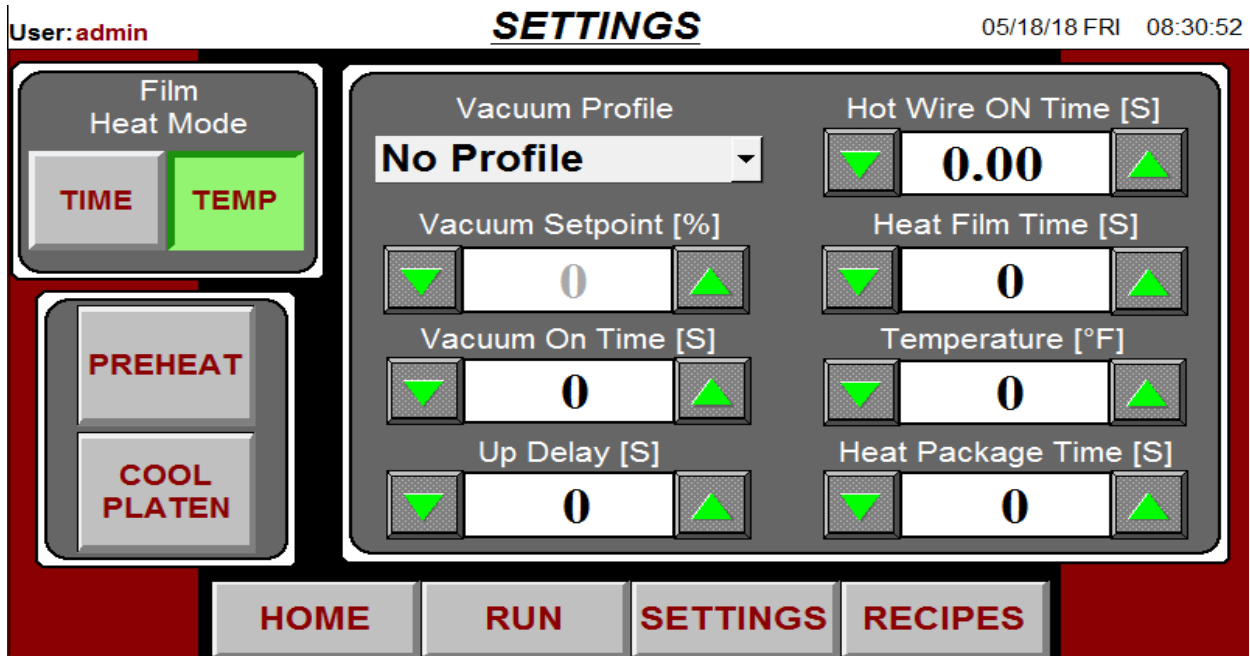

User: **SETTINGS** 04/23/19 TUE 09:51:52

Cool Platen

Cooling Platen Timeout

Cooling Platen Vac Speed

Pre-Heat

Pre-Heat Duty Cycle

Heat Mode

Hot Wire ON Delay

User: **maint** **SETTINGS** 04/23/19 TUE 09:53:28

MACHINE OPTION SELECTION

STANDARD

INFEED ONLY

OUTFEED ONLY

INFEED & OUTFEED

AUTO

MANUAL

MUST BE IN MANUAL MODE TO CHANGE THIS SETTING.

NOTE: POWER TO THE MACHINE MUST BE CYCLED FOR CHANGES TO TAKE EFFECT.

The RECIPES screen allows users to save the current settings to a specific recipe to be loaded at another time. Up to (10) recipes can be saved at a time with each being able to be given its own unique name

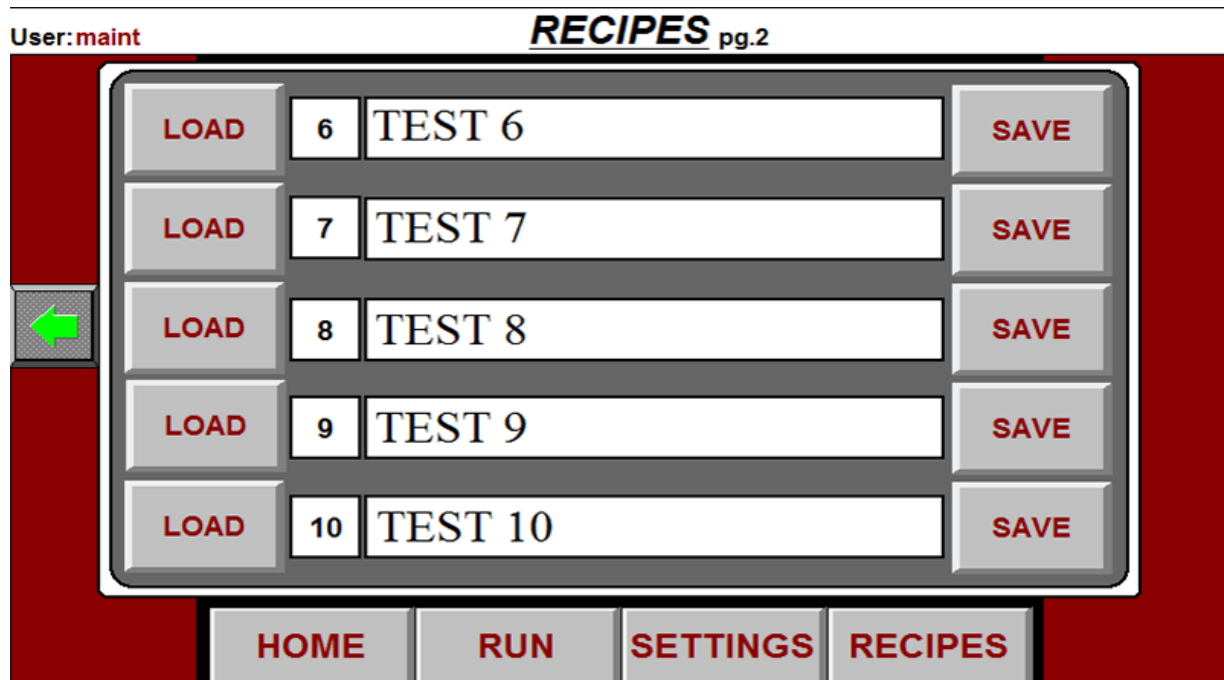
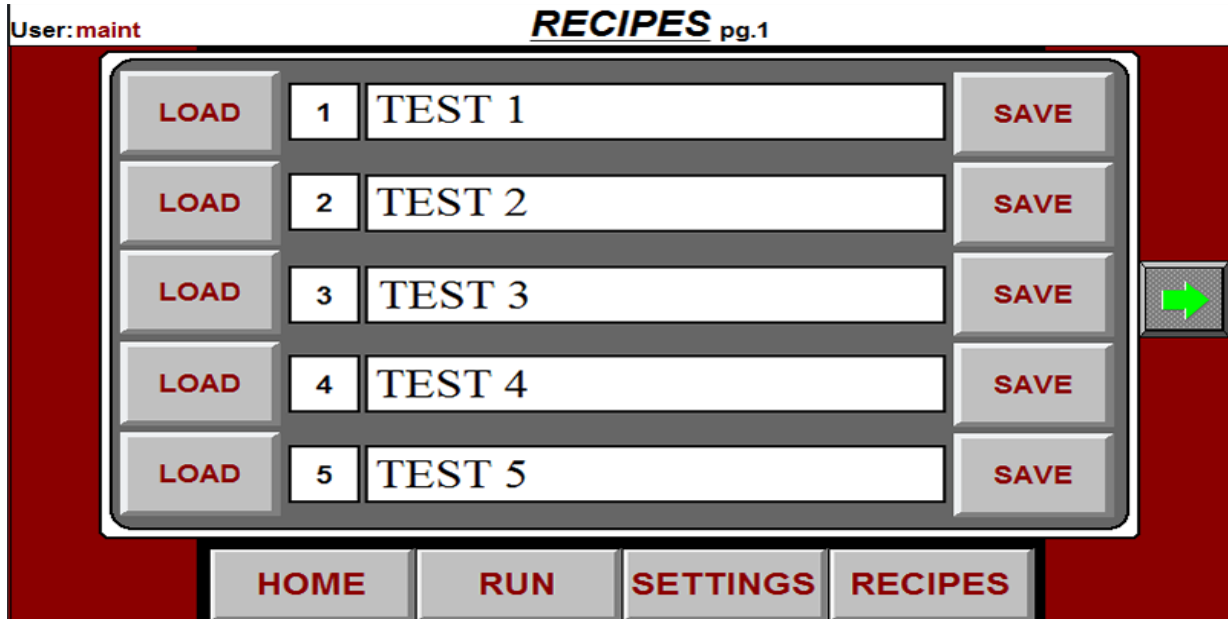

This screen display all the inputs from the PLC. This grants maintenance personnel the ability to monitor the inputs of the PLC without needing to open the panel. When an input is energized, the green light will illuminate

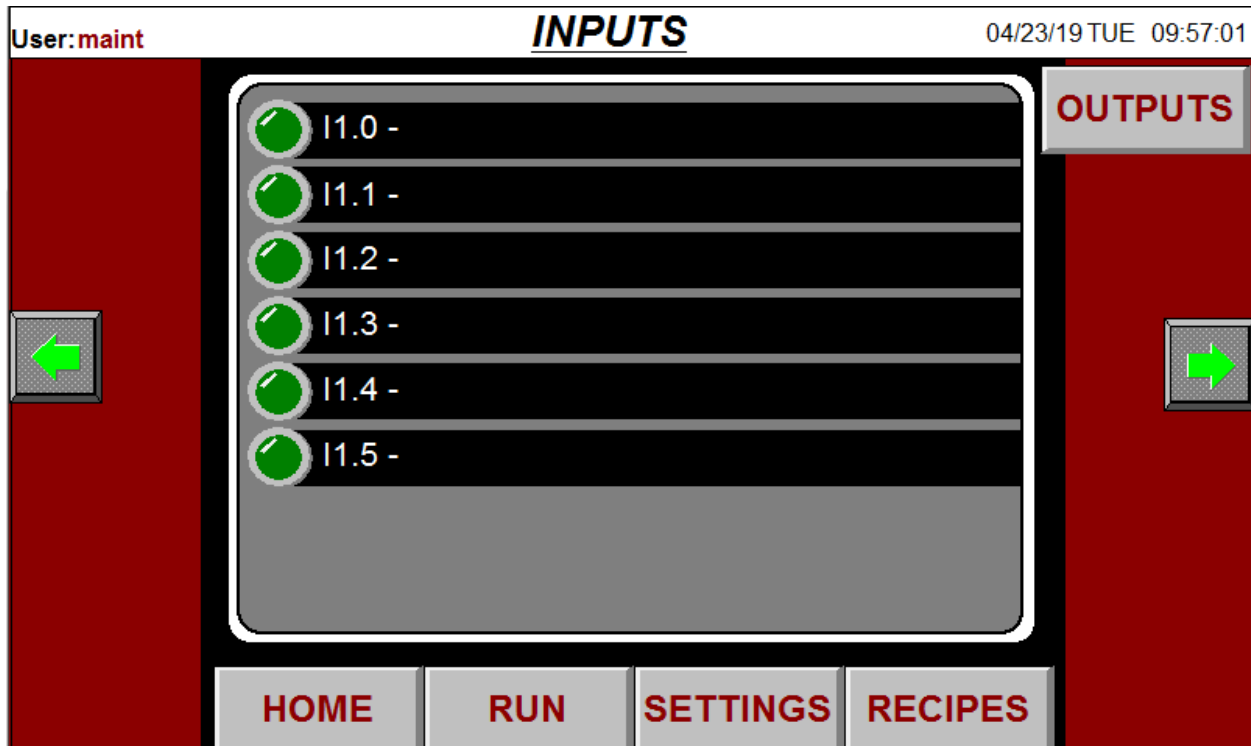
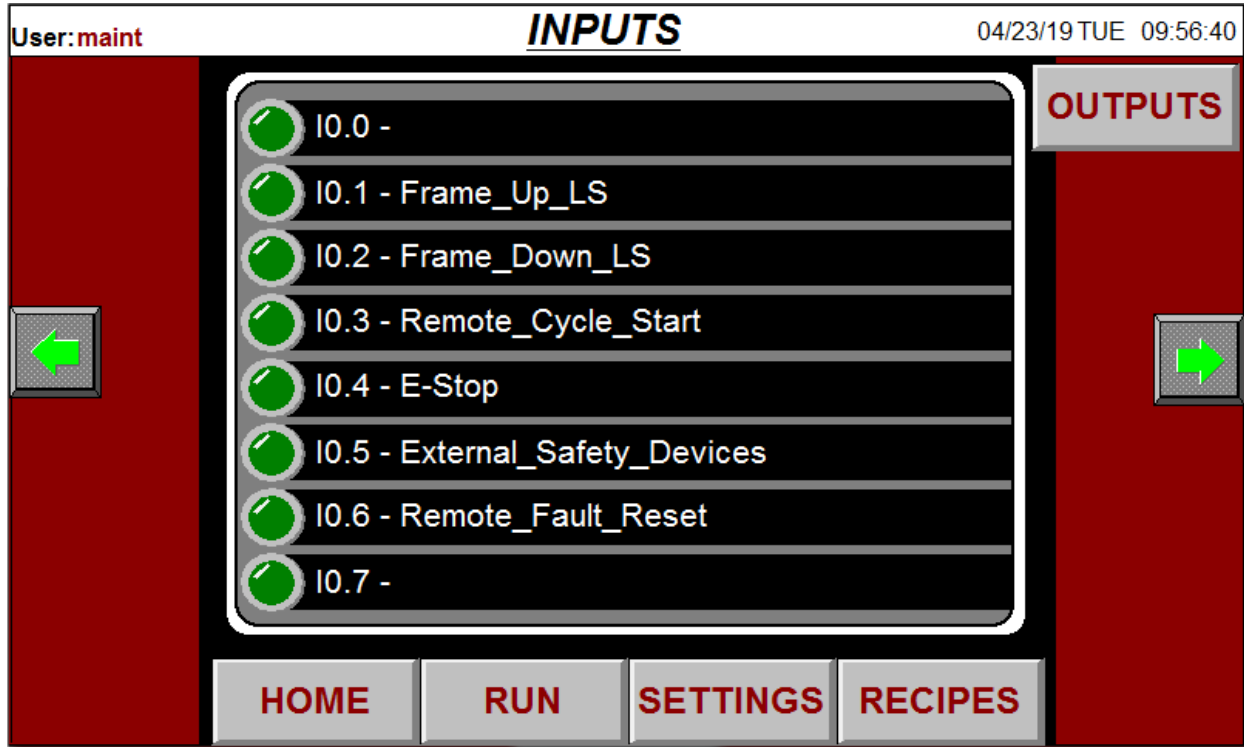

This screen display all the outputs from the PLC. This grants maintenance personnel the ability to monitor the outputs of the PLC without needing to open the panel. When an output is energized, the green light will illuminate.

User:maint **OUTPUTS** 04/23/19 TUE 09:58:21

INPUTS

- Q0.0 - Platen_Up / Frame_Open
- Q0.1 - Platen_Down / Frame_Close
- Q0.2 - Magnets_On
- Q0.3 - Hot_Wire_On
- Q0.4 - Film_Frame_Up
- Q0.5 - Film_Frame_Down
- Q0.6 - Oven_On
- Q0.7 - Mute Safety Control Output 1

HOME RUN SETTINGS RECIPES

User:maint **OUTPUTS** 04/23/19 TUE 09:58:40

INPUTS

- Q1.0 - Vacuum_Turbine_On
- Q1.1 - Mute Safety Control Ouput 2

HOME RUN SETTINGS RECIPES

User:maint **OUTPUTS** 04/23/19 TUE 09:59:03

INPUTS

- Q8.0 - Table_Cylinder_In
- Q8.1 - Table_Cylinder_Out
- Q8.2 - Card_Feeder_In
- Q8.3 - Card_Feeder_Back
- Q8.4 - Gripper_Down
- Q8.5 - Gripper_Up
- Q8.6 - Gripper_Carriage_In
- Q8.7 - Gripper_Carriage_Out

← →

HOME RUN SETTINGS RECIPES

User:maint **OUTPUTS** 04/23/19 TUE 09:59:28

INPUTS

- Q9.0 - Gripper_Close
- Q9.1 - Conveyor_Down
- Q9.2 - Conveyor_Up
- Q9.3 - Template_Up
- Q9.4 - Template_Down
- Q9.5 - Spare
- Q9.6 - Spare
- Q9.7 - Spare

← →

HOME RUN SETTINGS RECIPES

The MAINTENANCE screen will allow the user to change between auto and manual mode. In auto mode, all of the buttons will be greyed out. Switching to manual mode will allow the operator to manually turn on/off the different outputs.

Auto Mode: In auto mode, no manual buttons are active and the machine must be cycled via the MAIN screen “Start” and “Stop” buttons.

Manual Mode: In manual mode, the buttons in the MAINTENANCE screens become active.

NOTE: When switching from manual mode to auto mode, the machine will return all of the outputs to their default state. The film frame will return to the lowered position, the frame will open, and the magnets, hot wire, vacuum turbine, and oven will all turn off.

This screen is password protected.

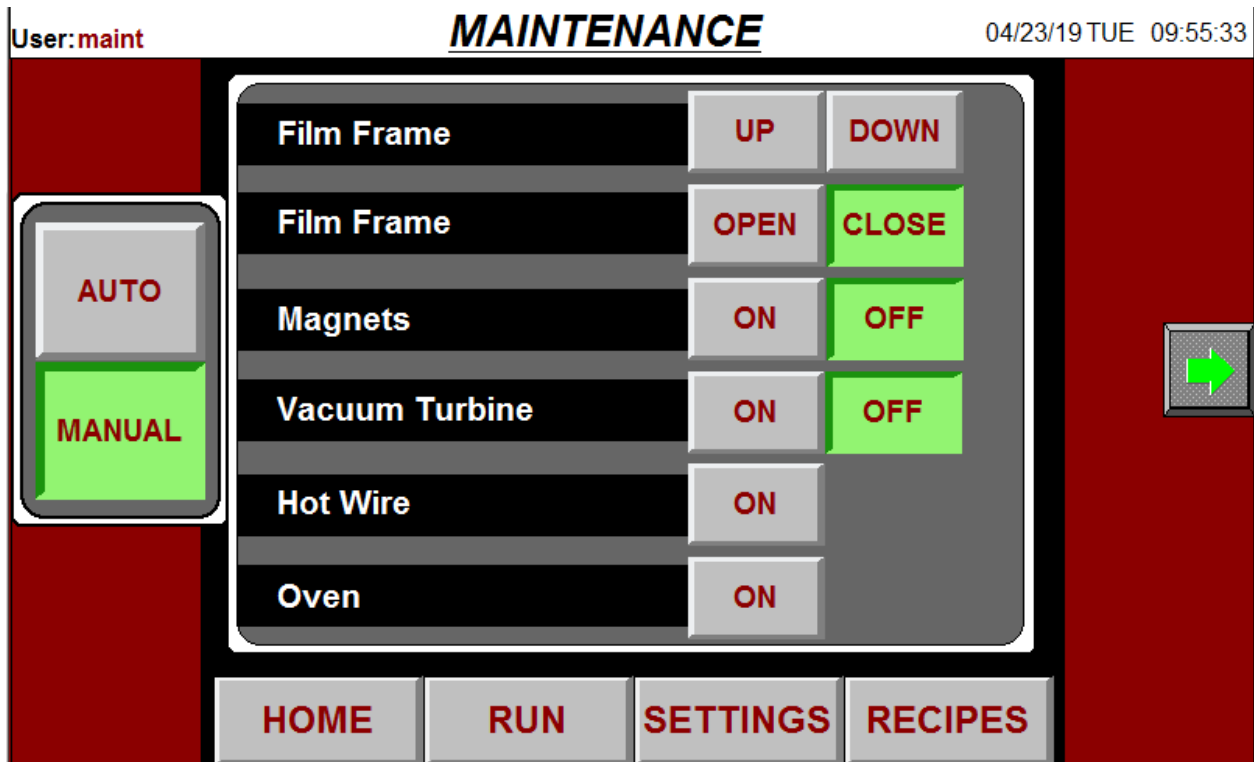

User:maint

MAINTENANCE

04/23/19 TUE 09:56:09

<u>INFEED</u>			<u>OUTFEED</u>		
Table Cylinder	IN	OUT	Gripper Arm	UP	DOWN
Card Feeder	IN	OUT	Gripper Carriage	IN	OUT
			Gripper Jaw	CLOSE	OPEN
			Conveyor	UP	DOWN

HOME RUN SETTINGS RECIPES

The ALARMS screen displays active alarms as well as when the alarm (s) occurred.

User: **maint** **ALARMS**

DATE	ALARM TIME	MESSAGE
07/03/18	10:55:14	Vat 2 temperature (175 degrees) exceeds safe limit!
07/03/18	10:55:09	Vat 2 temperature (175 degrees) exceeds safe limit!
07/03/18	10:54:34	Vat 2 temperature (175 degrees) exceeds safe limit!
07/03/18	10:54:29	Vat 2 temperature (175 degrees) exceeds safe limit!
07/03/18	10:53:54	Vat 2 temperature (175 degrees) exceeds safe limit!
07/03/18	10:53:49	Vat 2 temperature (175 degrees) exceeds safe limit!
07/03/18	10:53:14	Vat 2 temperature (175 degrees) exceeds safe limit!
07/03/18	10:53:09	Vat 2 temperature (175 degrees) exceeds safe limit!
07/03/18	10:52:42	Danger Will Robinson!!
07/03/18	10:52:40	Danger Will Robinson!!
07/03/18	10:52:34	Vat 2 temperature (175 degrees) exceeds safe limit!

HOME RUN SETTINGS RECIPES

<u>Alarm</u>	<u>Description</u>	<u>Solution</u>
Film Frame Open/Close Alarm	Film frame open or opening when frame is raised or raising.	Check frame down limit switch and make sure the input is being seen when the frame is open or attempting to open.
Film Frame Up/Down Alarm	Film frame is getting a signal to raise and lower at the same time.	Turn off machine and contact your local distributor for assistance.
E-Stop Alarm	E-Stop has been pressed.	Pull E-stop out and reset the alarm.
External Safety Devices Alarm	External safety devices have changed state and are no longer delivering a signal to the input of the PLC.	Reset third party safety devices and ensure 24VDC is being delivered to the input of the PLC.

Some of the screens are password protected. The LOGIN screen allows the user to log in/out of different levels of authority. Upon power up the default user is logged in which has limited access to certain screens. Maintenance personnel and authorized individuals can use the following credentials to access all of the screens:

Username: **maint**

Password: **4922**

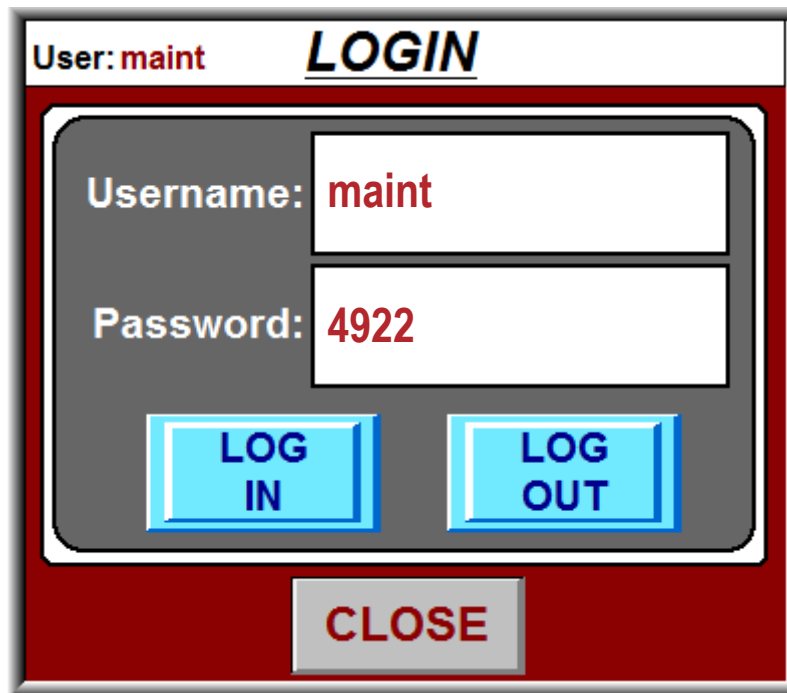

The screenshot shows a login interface with a red border. At the top left, it says "User: **maint**". To the right of this is the word "**LOGIN**" in a large, bold, black font. Below this, there are two input fields. The first is labeled "Username:" and contains the text "**maint**". The second is labeled "Password:" and contains the text "**4922**". Below the input fields are two blue buttons with white text: "LOG IN" on the left and "LOG OUT" on the right. At the bottom center of the screen is a grey button with red text that says "CLOSE".



The INFORMATION screen depicted below provides the user with Heat Seal's contact information. Please feel free to contact us with any questions, comments, or concerns!

User: **admin**

INFORMATION



Heat Seal, LLC.
4922 East 49th Street, Suite 100
Cleveland, Ohio 44125
(216)341-2022
www.HeatSealco.com



Made in the U.S.A.

HOME	RUN	SETTINGS	RECIPES
-------------	------------	-----------------	----------------



MAINTENANCE

- Drain water from the air filter reservoir regularly.
- Keep the top of the oven clear of clutter and occasionally wipe off any accumulated dust. This allows for proper heat dissipation.
- Occasionally check the tightness of all fittings, fasteners and electrical connections.
- Remove platen and clean vacuum box regularly to remove loose particles and keep vacuum screen clear.

REPLACING THE CUTOFF WIRE



- REMOVE OLD WIRE
- IF NEEDED, REPLACE INSULATION STRIP
- REMOVE OLD STRIP
- CLEAN SURFACE WITH BRAKE CLEANER OR OTHER SOLVENT TO REMOVE ALL ADHESIVE RESIDUE AND ANY DIRT OR GRIME
- CUT NEW STRIP TO LENGTH AND STICK TO SURFACE

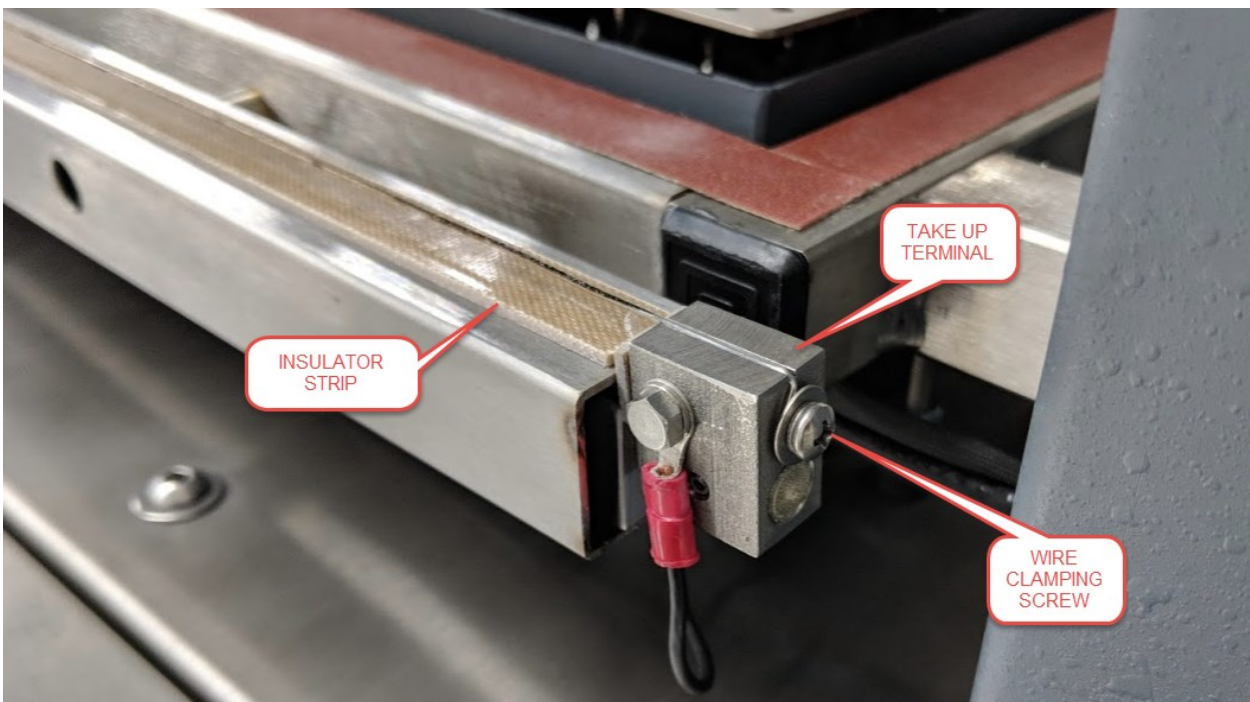

- LOOSEN SCREW ON BACK OF TAKE UP TERMINAL
- FORM A SMALL HOOK WITH THE WIRE AND LOOP IT AROUND THE CLAMPING SCREW.
- WHILE HOLDING WIRE, TIGHTEN SCREW
- ROUTE WIRE THROUGH THE GROOVE ON THE TOP OF THE TAKE UP TERMINAL AND THROUGH THE HOLE ON THE TENSIONING BOLT ON THE OPPOSITE END OF THE CUT-OFF ASSEMBLY

REPLACING THE CUTOFF WIRE

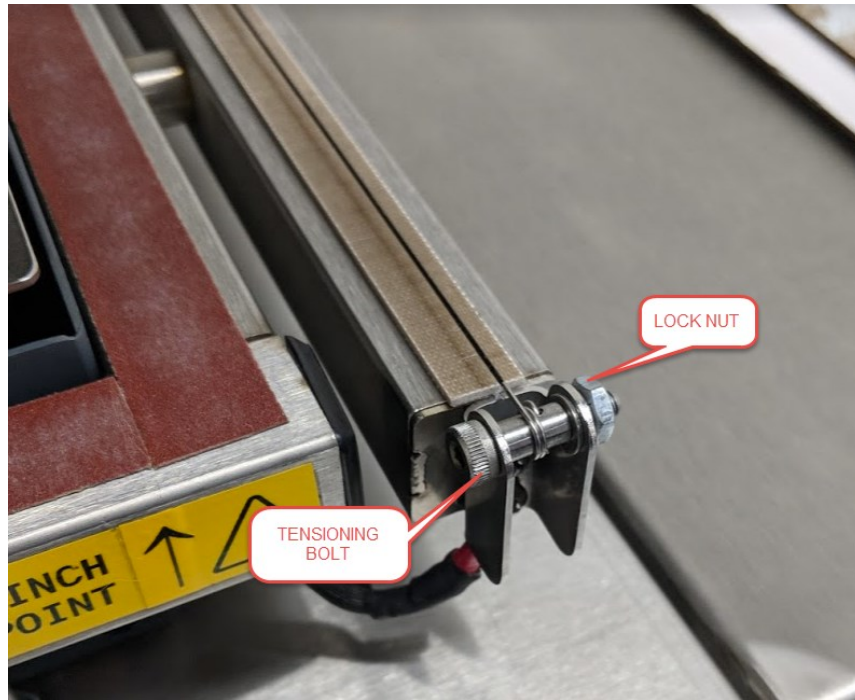

- WITH THE LOCK NUT LOOSE, TURN THE TENSION BOLT USING A 1/8" HEX WRENCH TO WIND THE WIRE AROUND THE BOLT.
- TO ENSURE A GOOD ELECTRICAL CONNECTION, MAKE SURE THE WIRE WRAPS AROUND THE BOLT AT LEAST 2 TIMES.
- TURN THE BOLT UNTIL THE TAKE UP TERMINAL INSULATION STRIP IS BOTTOMED OUT ON THE BASE.

REPLACING THE CUTOFF WIRE



WARNING:

MAKE SURE THE TAKE UP TERMINAL INSULATION STRIP IS ATTACHED TO TAKE UP TERMINAL. OTHERWISE AN ELECTRICAL SHORT MAY BE CAUSED.

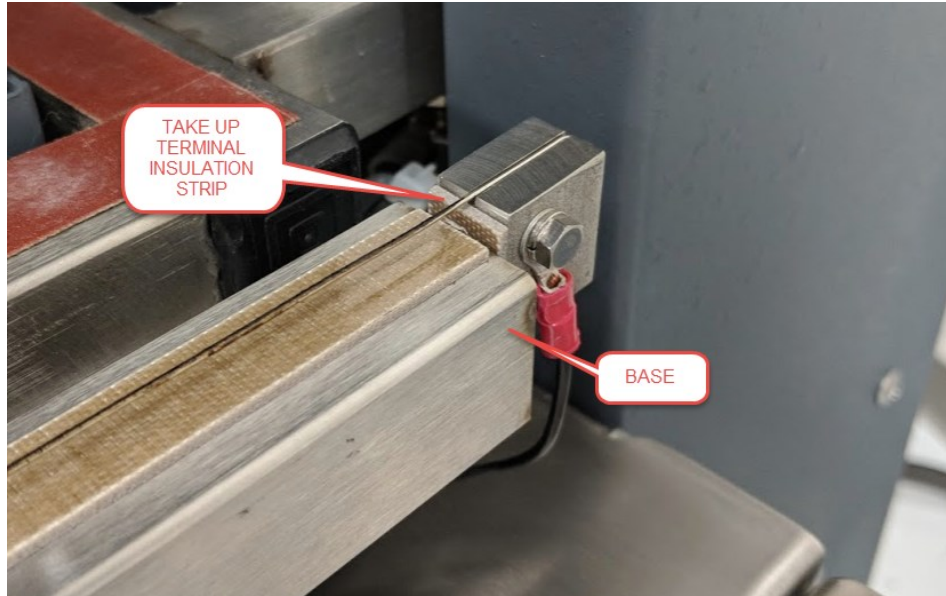

- WITH THE TAKE UP TERMINAL BOTTOMED OUT AGAINST THE BASE, THE WIRE IS FULLY TENSIONED. WHILE HOLDING THE TENSION BOLT IN PLACE WITH THE HEX WRENCH, TIGHTEN THE LOCK NUT TO HOLD THE WIRE IN PLACE.

FEATURES ON MASTER SKIN MACHINE

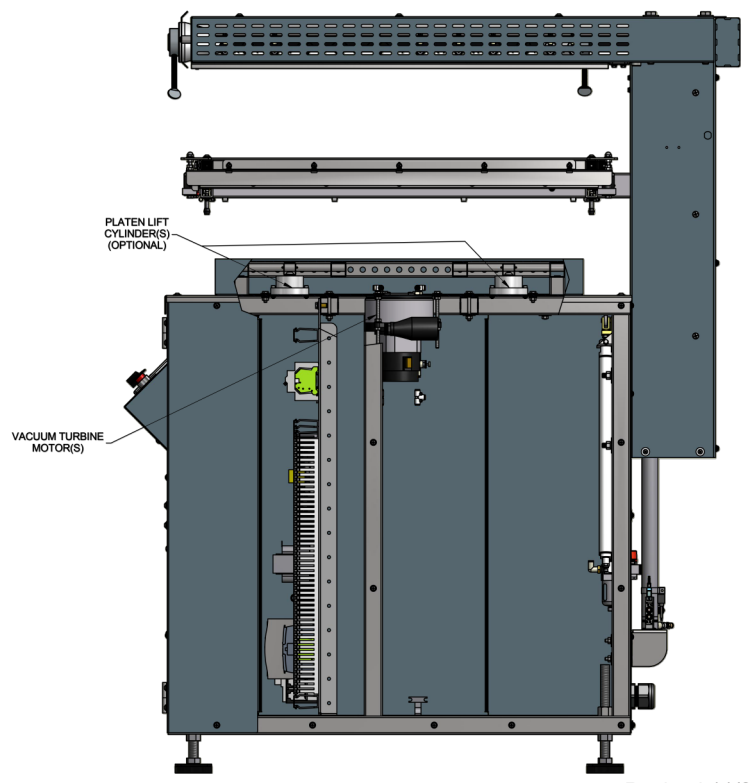
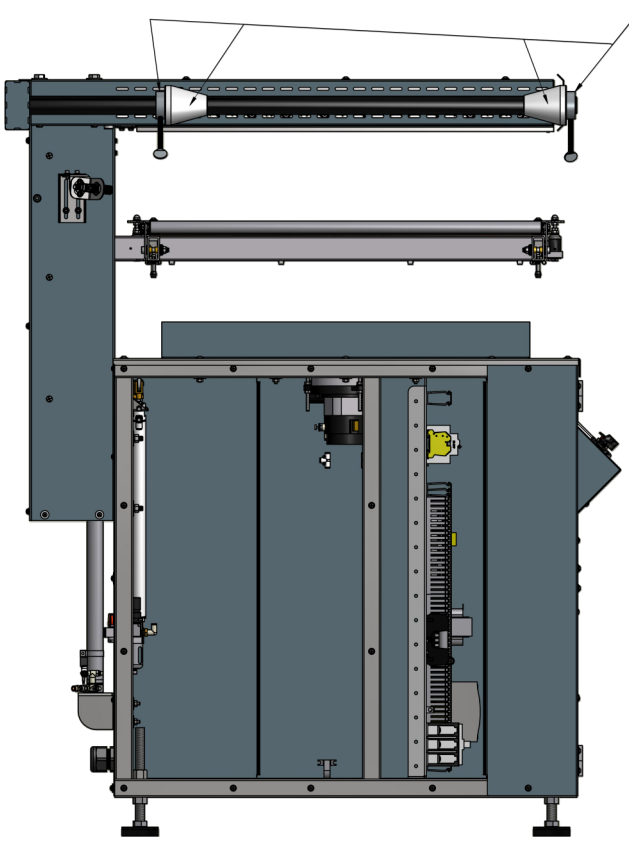
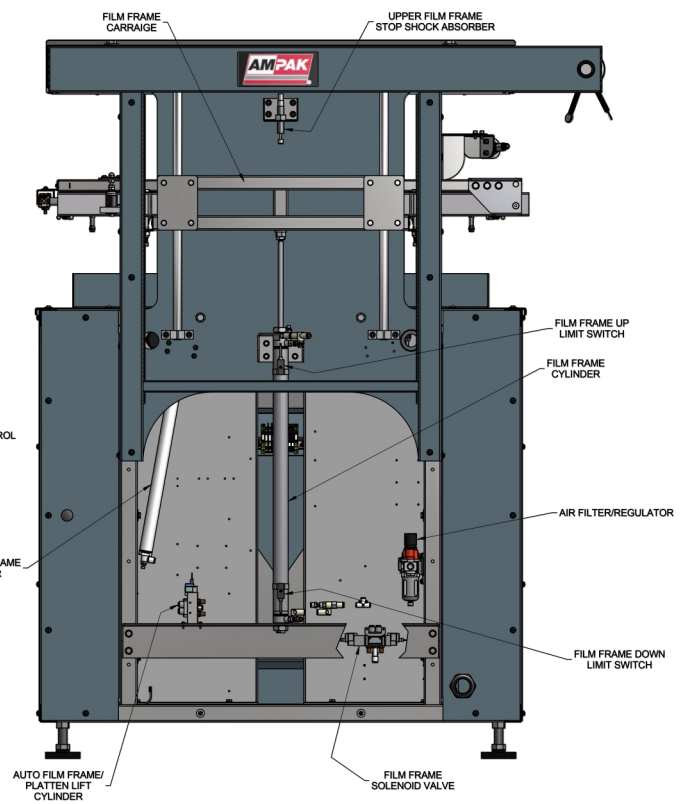
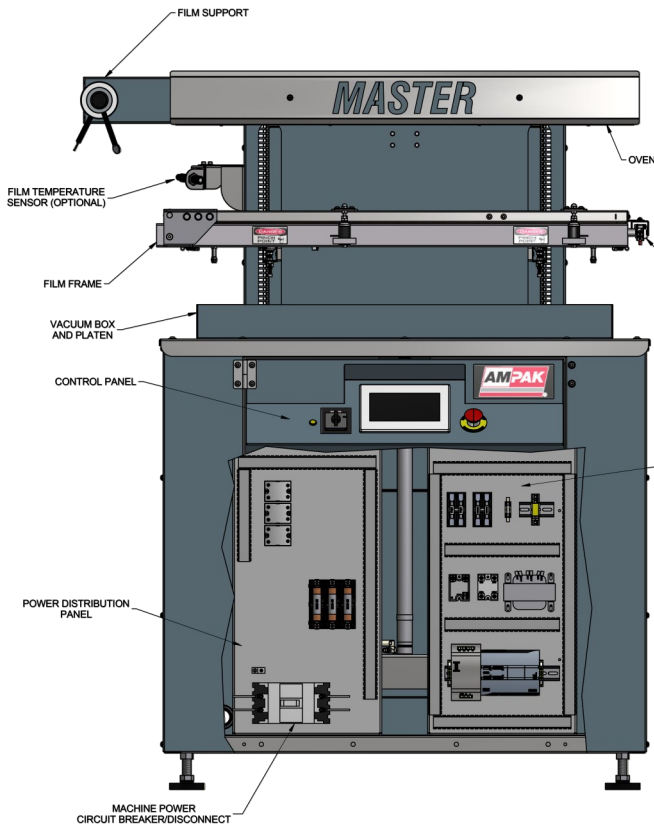

Revised 11/22

ORDERING PARTS



- Before calling our Customer Service department, please obtain the model and serial number from the machine nameplate usually located on the back side of your equipment.
 - If you know the part number, we can usually help you very quickly. If you don't know the part number, it usually requires research on our part and a return call from our technician. Please give as much information as possible to the technician in his search for what you need. The technicians first priority is to help troubleshoot problems over the phone, parts research therefore, must be done as time permits. Please be patient as the technician will return your call as quickly as possible.
 - We welcome sketches, drawings, & pictures sent by fax or e-mail to aid in your part identification. See the contact information on the back cover for how to contact the Ampak Customer Service department.
 - Parts that are in stock can usually ship the same day. However, if a part requires assembly, programming or inspection, it may require additional time to ensure that the part you buy is correct and performs in working order. We make every effort to ship your part as quickly as possible.
 - Part orders weighing less than 75 lbs. (34.02 kg) are normally shipped UPS Surface. Second day or overnight service by UPS or FedEx is available. Shipping charges will be billed to the customer. In order for your parts to be shipped overnight via FedEx standard air, we will need to know your FedEx Shipper identification number before we can ship. All part shipments are F.O.B. Cleveland, Ohio.
 - Larger and heavier parts (above 75 lbs.) Are normally shipped via common carriers F.O.B. Cleveland. Air freight is available at your expense. All parts orders must be received with a valid purchase order when calling Customer Service.
- ## WARRANTIED PARTS
- Parts ordered under the machine warranty are handled the same as above except that a Return Authorization number is issued for the defective part. This RA number is given verbally at the time of the order. When returning the defective part(s) to the factory, be sure the RA number is written and clearly visible on the outside of the packaging or crating so it can be routed to the appropriate department once it is received by Ampak.
 - This RA number will insure you receive proper credit to your account. Credits are usually issued within thirty (30) days of the receipt of the defective part. Failure to return defective part or any evidence of damage caused by unauthorized use will prevent credit from being issued.
 - See Warranty Information, Page 5 for further information.

TROUBLESHOOTING



Master/Shipmate HMI ALARMS			
Alarm Message	What causes alarm to trigger?	Possible Issues	Possible Solutions
Magnets alarm. See manual for details.	<ul style="list-style-type: none"> • Magnets are turned on (Q0.2) and the film frame is being told to open. 	<ul style="list-style-type: none"> • Operator error while using manual controls. 	<ul style="list-style-type: none"> • Ensure magnets are turned off before attempting to open the film frame.
E-Stop has been pressed.	<ul style="list-style-type: none"> • Loss of 24VDC to I0.4 on the PLC. 	<ul style="list-style-type: none"> • E-stop pressed. • Bad/faulty E-Stop pushbutton and/or contact block. 	<ul style="list-style-type: none"> • Turn E-stop knob to release then reset alarm. • Replace E-Stop pushbutton. • Replace E-Stop contact block.
External safety device has been tripped. Signal lost to I0.5.	<ul style="list-style-type: none"> • Loss of 24VDC to I0.5 on the PLC. 	<ul style="list-style-type: none"> • External safety device is tripped and has not been reset. • External safety device not connected. 	<ul style="list-style-type: none"> • Reconnect safety device to get 24V back to input 0.5 on the PLC. • Make sure there is no split or disconnected wire between the safety device and PLC input.
Infeed table alarm. See manual for details.	<ul style="list-style-type: none"> • The limit switch that tell the PLC that the infeed table has extended into the seal area of the machine is currently energized and the frame is moving down or the Frame Down pushbutton has been pressed. • The limit switch that tells the PLC that the film frame is in the down position is currently energized and the infeed table is trying to extend into the seal area or the Extend Infeed Table pushbutton has been pressed. 	<ul style="list-style-type: none"> • Bad/faulty Table In Limit Switch (I8.0) • Bad/faulty Frame Down Limit Switch (I0.2) • Operator error while using manual controls. 	<ul style="list-style-type: none"> • Replace Table In Limit Switch. • Replace Frame Down Limit Switch.
Gripper carriage alarm. See manual for details.	<ul style="list-style-type: none"> • The limit switch that tell the PLC that the gripper carriage is extended into the sealing area is currently energized while the film frame moving up or the Frame Up pushbutton has been pressed. • The limit switch that tells the PLC that the film frame is in the up position is currently energized while the gripper carriage is extending into the seal area of the Extend Grippers pushbutton has been pressed. 	<ul style="list-style-type: none"> • Bad/faulty Gripper Carriage In Limit Switch (I8.4) • Bad/faulty Frame Up Limit Switch (I0.1) • Operator error while using manual controls 	<ul style="list-style-type: none"> • Replace Gripper Carriage In Limit Switch. • Replace Frame Up Limit Switch.
Temperature sensor either not functioning or not connected.	<ul style="list-style-type: none"> • If, in the settings screens, TEMP is selected in the Heat Mode selection box and the temperature feedback is zero or less. 	<ul style="list-style-type: none"> • Bad/faulty temperature sensor. • Bad/faulty communication cable. • Bad/faulty input on PLC. • Loose/severed connection between PLC and temperature sensor. • No sensor connected. 	<ul style="list-style-type: none"> • Ensure your machine is equipped with a temperature sensor. • Make sure the cable is tightly screwed into the back of the sensor. • Replace necessary faulty component. • Check cable for splits, kinks, cuts. Replace is necessary.

TROUBLESHOOTING



PROBLEM	PROBABLE CAUSES
POWER ON LIGHT WILL NOT LIGHT	<ul style="list-style-type: none"> • Light bulb burnt out. • Main breaker tripped. • No power to machine.
MACHINE WILL NOT CYCLE	<ul style="list-style-type: none"> • No air pressure. • Frame not completely down or up. • Frame limit switches need adjusting.
HEAT FILM CYCLE WILL NOT START <ul style="list-style-type: none"> • IF EQUIPPED WITH EZ-INFEED, PRODUCT NOT SET ON INFEED TABLE. • IF EQUIPPED WITH EZ-OUTFEED, PRODUCT DETECT PHOTO-EYE BROKEN. 	<ul style="list-style-type: none"> • Frame not completely down or up. • Frame limit switches need adjusting.
FILM FRAME WILL NOT LOWER	<ul style="list-style-type: none"> • No air pressure. • Make sure there is no obstruction in path of film frame.
VACUUM TURBINES WILL NOT RUN	<ul style="list-style-type: none"> • SC1 controller defective. • PLC output not functioning. • Make sure vacuum on time has value.
FILM CUTOFF WILL NOT WORK	<ul style="list-style-type: none"> • Cutoff wire burned or broken. • PLC output not functioning. • SSR4 is defective.
FILM CUTOFF WIRE BURNS OUT	<ul style="list-style-type: none"> • Hot wire on time set too high. • Wire tension set incorrectly.
FILM IS TOO HOT	<ul style="list-style-type: none"> • Film heat time is set too long. • Temperature setpoint is set too high. • Temperature sensor is defective.
OVEN DOES NOT TURN ON	<ul style="list-style-type: none"> • SSR1, SSR2, and/or SSR3 are defective. • PLC output not functioning.
OVEN FUSE BLOWN	<ul style="list-style-type: none"> • Spirad clips cracked or broken.

Revised 11/22

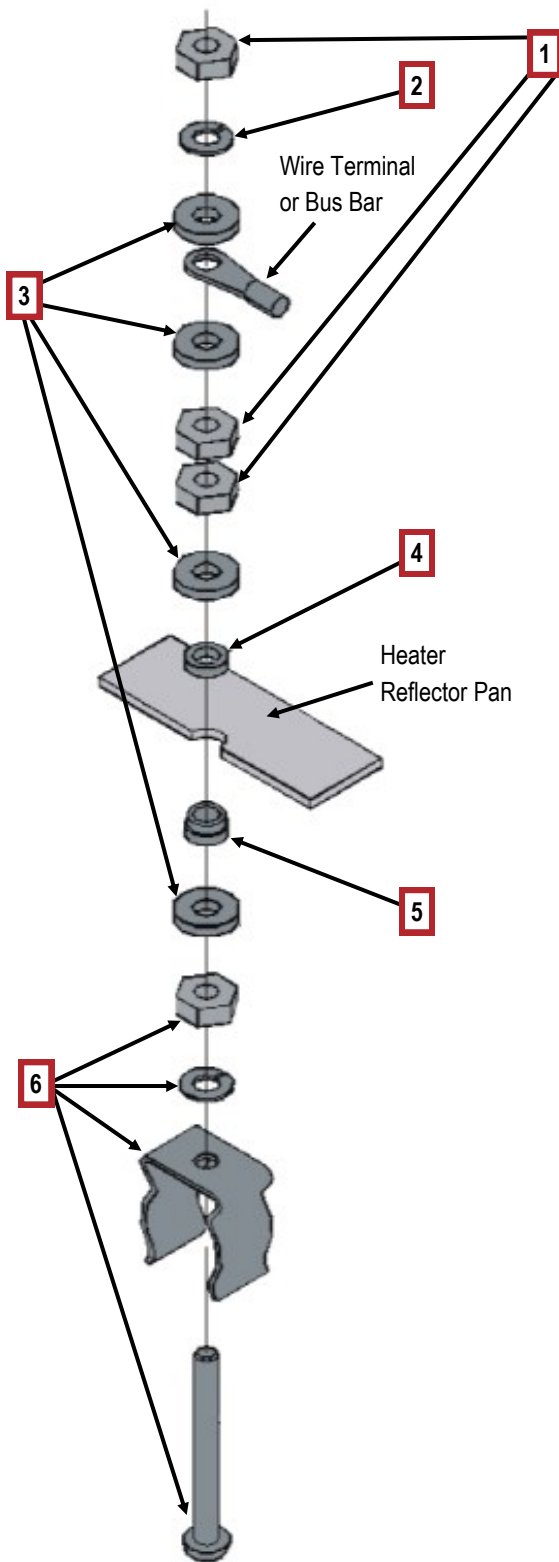

Item	Part #	Description
1	1911-005	#6 Hex Nut
2	1907-004	#6 Split Lock Washer
3	1909-007	#6 Flat Washer
4	440009	Female Ceramic Washer
5	440008	Ceramic Bushing
6	017612	Spirad Clip Assembly

Due to restrictions imposed on Ampak regarding the liability involved in shipping Spirads®, the following policies are set forth:

- Spirad elements, regardless of size, are shipped from the factory in quantities of three to each order.
- Always open and inspect Spirad shipments for damage immediately upon receipt. If broken Spirads are discovered, contact Ampak customer service immediately. Damage claims must be filed quickly to allow for replacements and/or adjustments.

Order replacement Spirads by machine model and voltage.

REMOVING SPIRADS FOR SERVICING

ALWAYS TURN OFF MAIN CIRCUIT BREAKER BEFORE WORKING IN THE OVEN. WEAR SAFETY GLASSES WHEN HANDLING SPIRADS

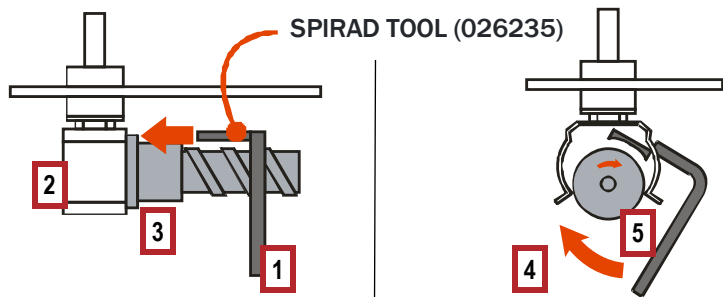

Insert Tool (1) Between Clip (2) and End Terminal (3) of Spirad Assembly

Pull Slowly In The Direction Of The Arrow (4) Above And Let Spirad (5) Roll Out Of Clip

SPIRAD INSPECTION & REPLACEMENT



1. LOWER FILM FRAME AND TURN OFF MACHINE
2. TURN OFF MAIN BREAKER, CB1
3. REMOVE OVEN SCREEN(S)
4. USING SPIRAD REMOVAL TOOL, REMOVE SPIRAD TO BE REPLACED
 - a. INSERT PRONG OF TOOL IN GAP BETWEEN SPIRAD TERMINAL AND CLIP
 - b. CAREFULLY ROTATE TOOL BACK AND FORTH TO WORK SPIRAD LOOSE FROM CLIP
 - c. WHILE HOLDING SPIRAD, REPEAT ON OPPOSITE END OF SPIRAD

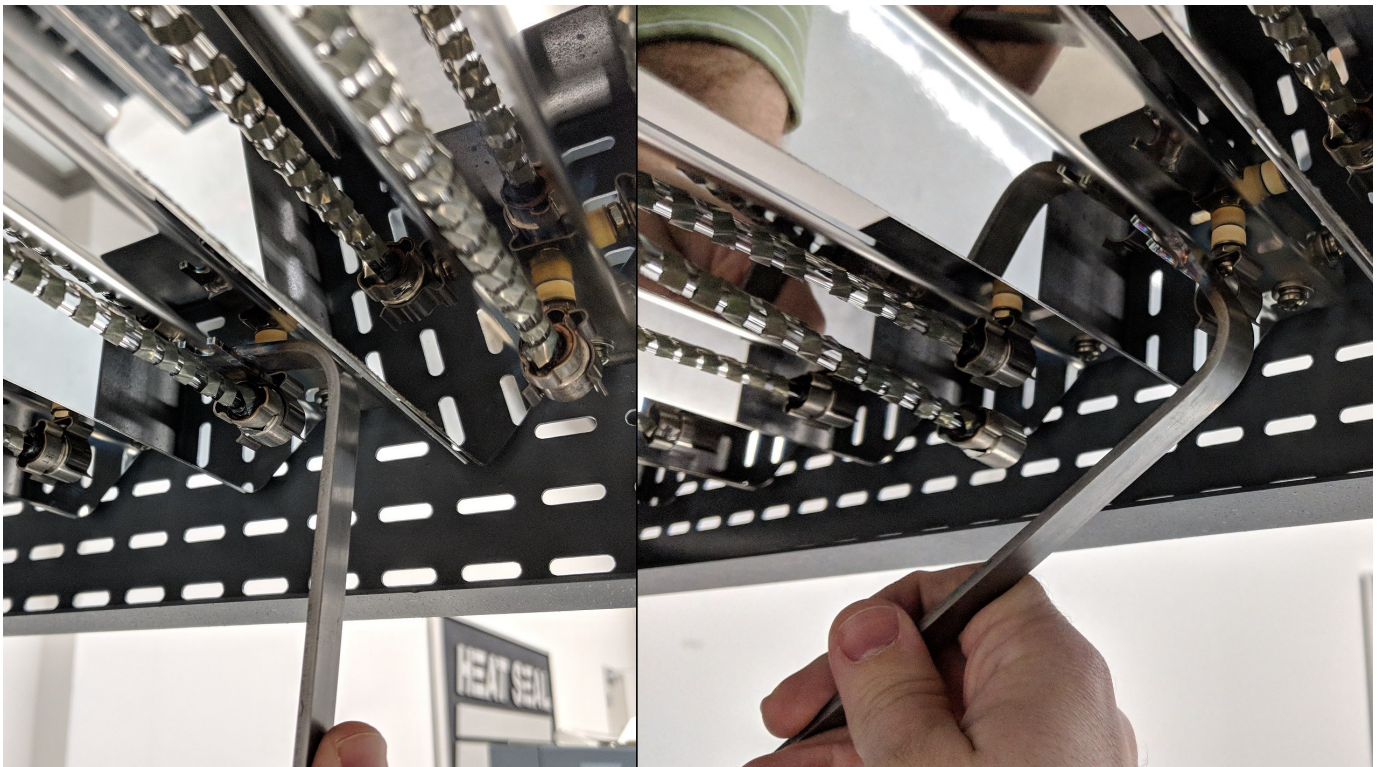

SPIRAD INSPECTION & REPLACEMENT



5. INSPECT NEW SPIRAD

- a. MAKE SURE THAT THERE IS AT LEAST A 1/16" GAP BETWEEN ALL COIL WINDINGS
- b. IF NEEDED, ADJUST THE COILS BY HAND TO ADJUST COIL SPACING
- c. IF COILS ARE IN CONTACT WITH EACH OTHER IT WILL CREATE A HOT SPOT IN THE SPIRAD AND WILL LEAD TO PREMATURE FAILURE
- d. SEE BELOW FOR EXAMPLES

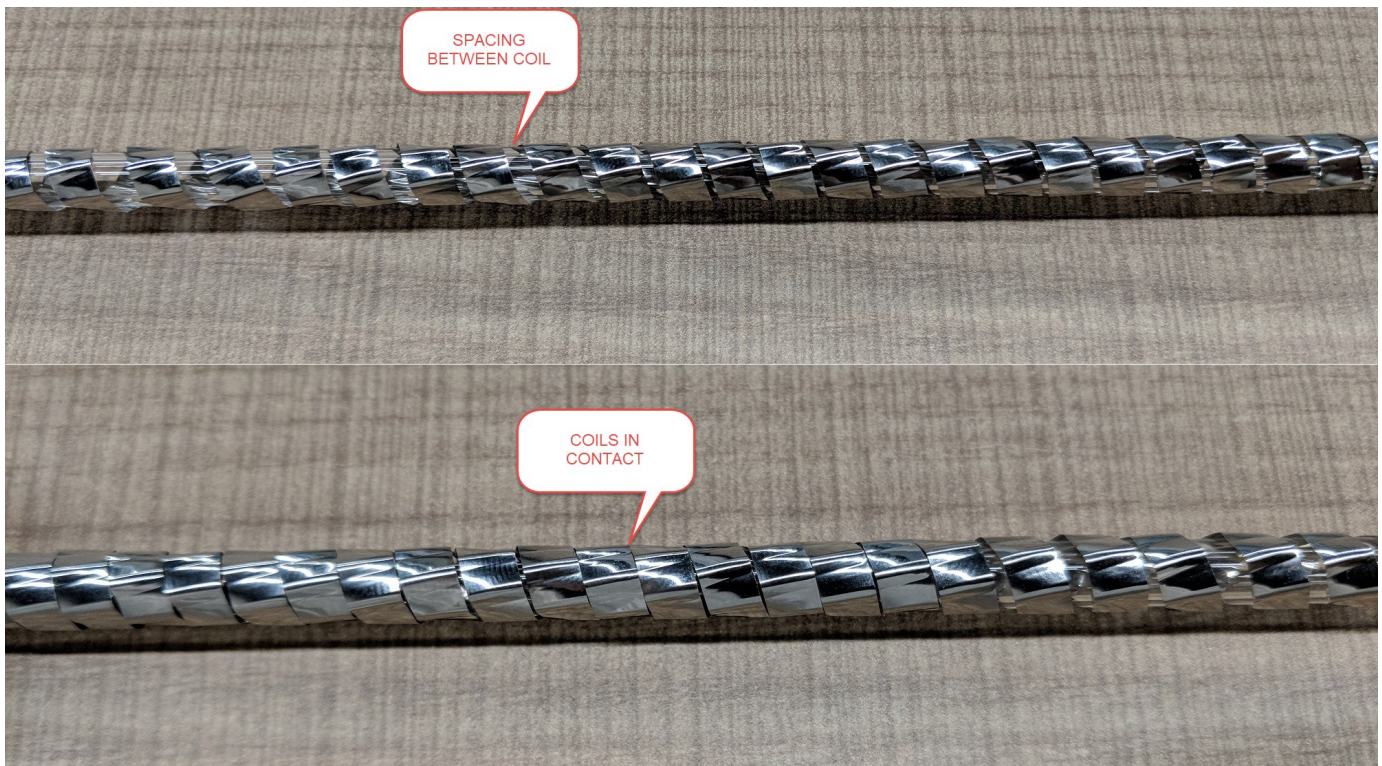

SPIRAD INSPECTION & REPLACEMENT



6. INSTALL NEW SPIRAD BY ALIGNING ENDS WITH CLIPS AND PRESSING INTO PLACE
7. TEST NEW SPIRADS BEFORE RE-INSTALLING OVEN SCREEN
 - a. REAPPLY POWER AND TURN ON MACHINE
 - b. LOGIN AS MAINT
 - c. FROM THE MAINTENANCE SCREEN SWITCH TO MANUAL MODE
 - d. TURN ON THE OVEN BY PRESSING AND HOLDING THE OVEN BUTTON
 - e. WITH THE OVEN ON, INSPECT THE NEW SPIRADS FOR HOT SPOTS. HOTS SPOTS ARE IDENTIFIED BY SEEING A BRIGHTER GLOW OF THE WIRE IN A SMALL AREA. SEE BELOW FOR EXAMPLES.

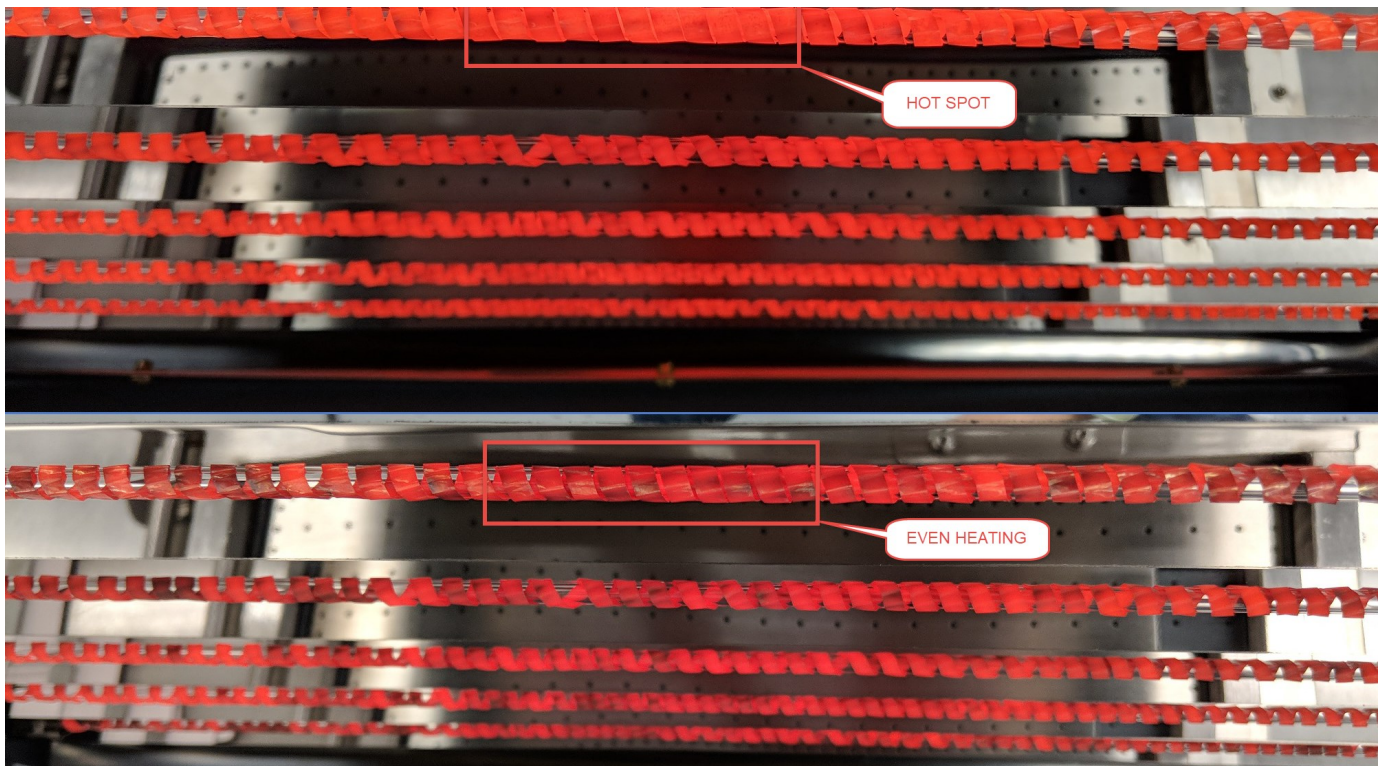

8. RE-INSTALL OVEN SCREEN

PNEUMATIC ASSEMBLY SP-MP2430

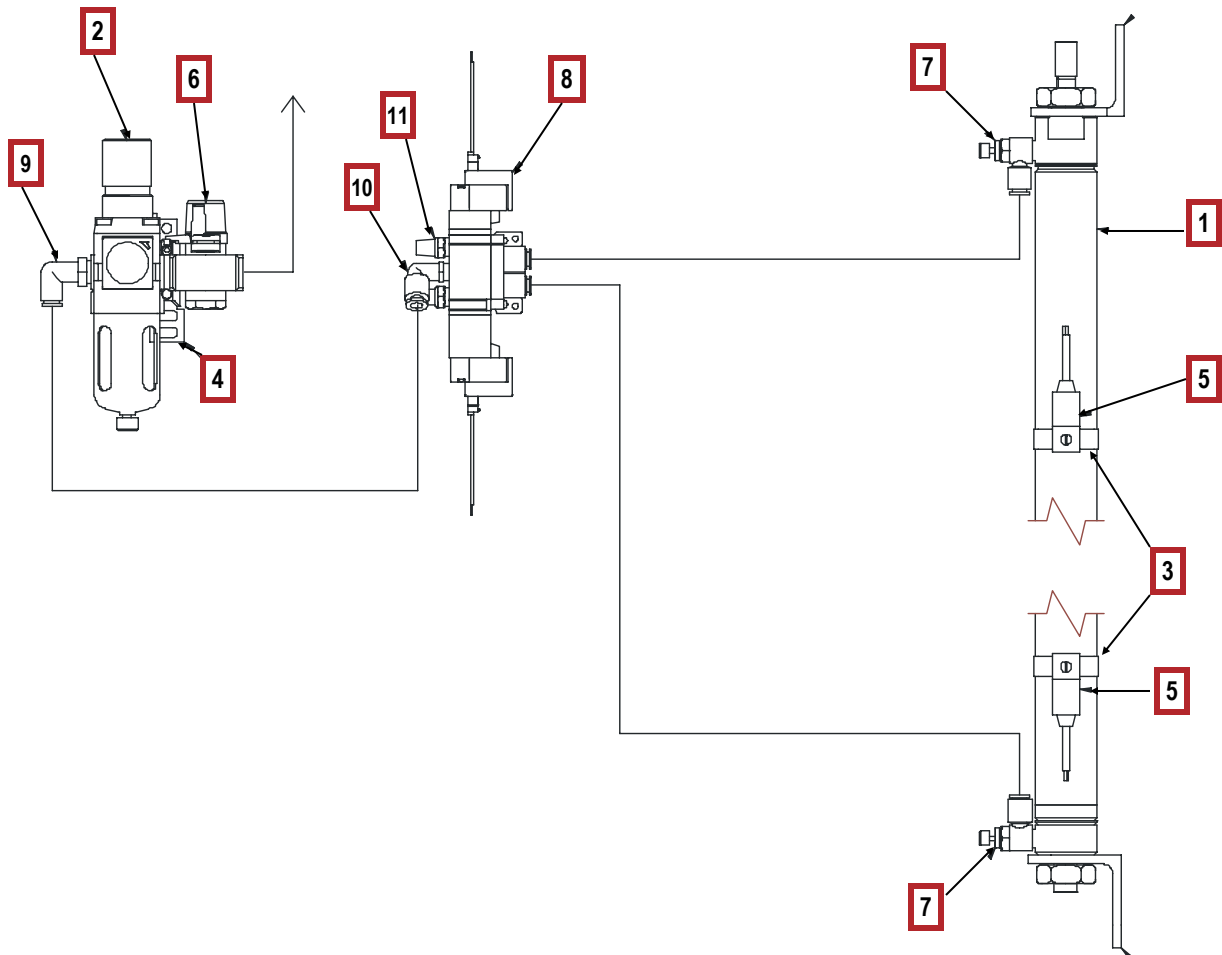

Item	Qty	Part #	Description
1	1	2160-106	CYLINDER, AIR - 1 1/4" BORE X 22" STROKE
2	1	2160-107	FILTER REGULATOR, 1/4 NPT, W/BUILT-IN GAUGE
3	2	2160-111	MOUNTING BAND, AUTO SWITCH
4	1	2160-112	SPACER, FILTER/REG. UNIT W/ BRKT
5	2	2160-113	SWITCH, REED, W/ BAND MOUNT - 24VDC - 200VAC
6	1	2160-115	VALVE, RELIEF, 1/4 NPT
7	2	2160-110	FLOW CONTROL, 1/8 NPT X 1/4 TUBE
8	1	2160-114	VALVE, 5 PORT, 3 POS, 24V, CENTER OFF, LIGHTED
9	1	70-303-0006	FITTING, ELBOW, 1/4NPT X 1/4 TUBE
10	1	70-303-0008	FITTING, 90 DEG ELBOW, 1/8 MALE NPT, 1/4 TUBE
11	2	AS0002165	MUFFLER, EXHAUST, 1/8" NPT

Revised 11/22

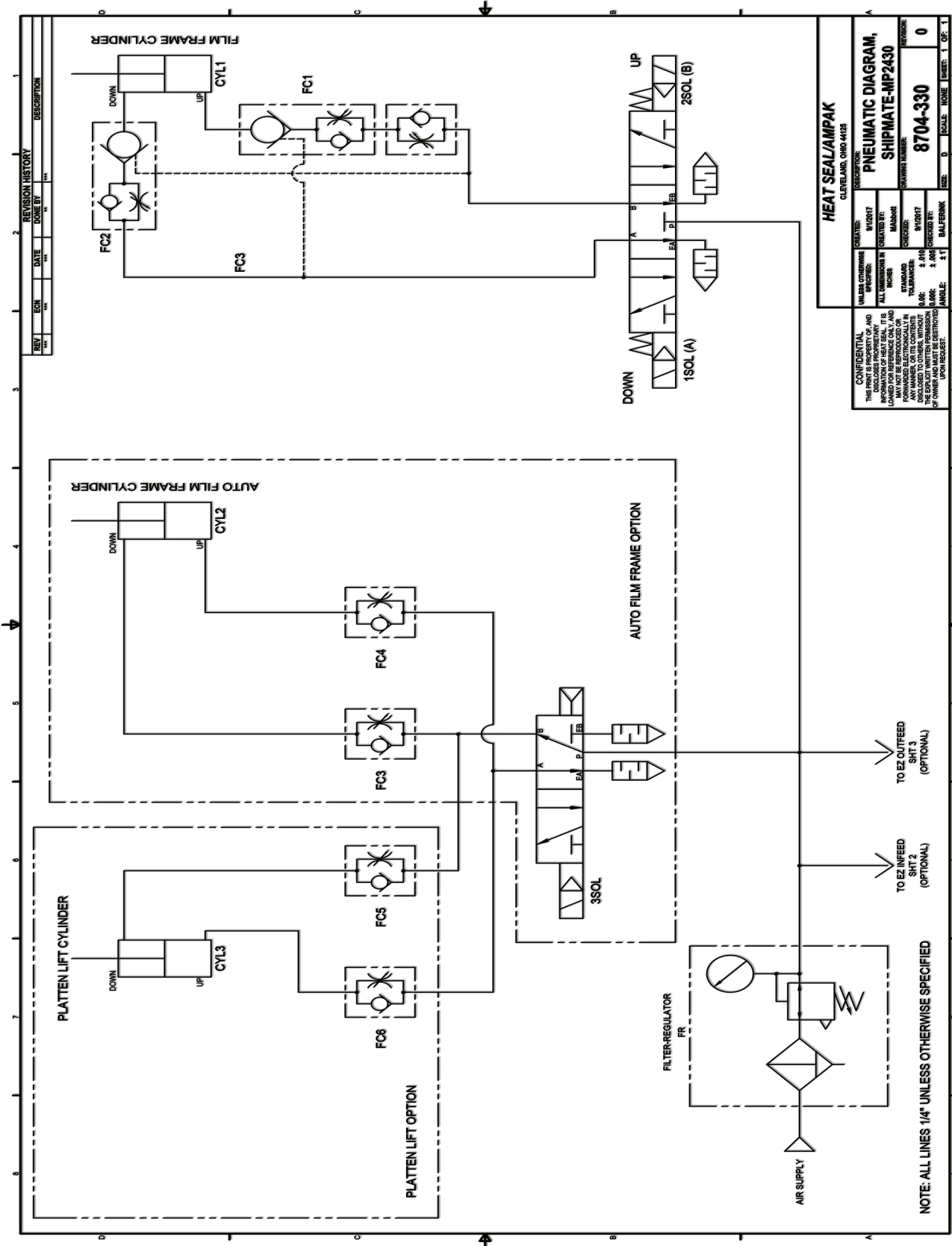

REVISION HISTORY		DESCRIPTION	
REV	EGN	DATE	DOING BY

HEAT SEAL/AMPAK CLEVELAND, OHIO 44125		DESIGNED BY: SH10017	REVISION:
DRAWN BY: MAN-041		ALL DIMENSIONS IN INCHES	SHIPMATE-MP2430
CHECKED BY: SH10017		STANDARD TOLERANCES:	DRAWING NUMBER: 8704-330
DATE: 2.11.07		SCALE: NONE	SHEET: 1 OF 1
DRAWN BY: MAN-041		DATE: 2.11.07	REVISED BY: 0

CONFIDENTIAL
THIS DRAWING IS THE PROPERTY OF HEAT SEAL/AMPAK AND IS NOT TO BE REPRODUCED OR TRANSMITTED IN ANY MANNER OR BY ANY MEANS, ELECTRONIC OR MECHANICAL, INCLUDING PHOTOCOPYING, RECORDING, OR BY ANY INFORMATION STORAGE AND RETRIEVAL SYSTEM, WITHOUT THE EXPRESS WRITTEN PERMISSION OF HEAT SEAL/AMPAK. VIOLATION OF THIS PERMISSION SHALL BE PROSECUTED.

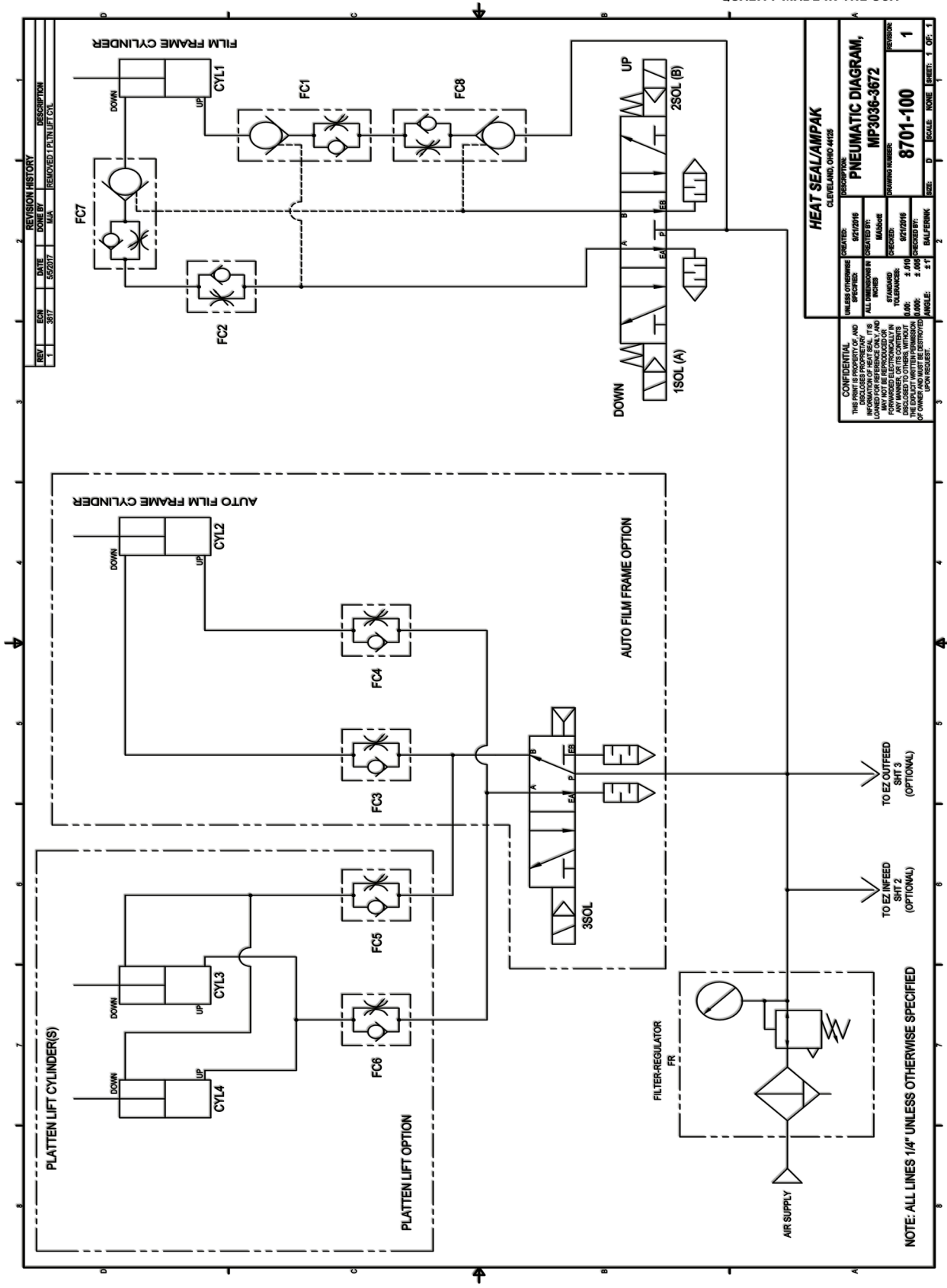

REV	ECN	DATE	DESIGNATION	DESCRIPTION
1	357	8/20/06	MVA	REMOVED 1 PLATTEN LIFT CYL

HEAT SEAL/AMPAK CLEVELAND, OHIO 44125	
DESIGNED BY:	8/21/2016
CHECKED BY:	8/21/2016
DATE:	8/21/2016
SCALE:	NONE
SHEET:	1 OF 1
PROJECT:	MP3036-3672
REVISED BY:	8/21/2016
DATE:	8/21/2016
SCALE:	1:1
SHEET:	1 OF 1

CONFIDENTIAL
THIS DRAWING IS THE PROPERTY OF HEAT SEAL/AMPAK AND IS NOT TO BE REPRODUCED, COPIED, LOANED OR REFERENCED IN ANY MANNER, OR ITS CONTENTS DISCLOSED OR TRANSMITTED IN ANY MANNER WITHOUT THE WRITTEN PERMISSION OF HEAT SEAL/AMPAK. VIOLATION OF THIS POLICY WILL RESULT IN SEVERE PENALTIES.

INFRARED SENSOR ASSEMBLY 8702081

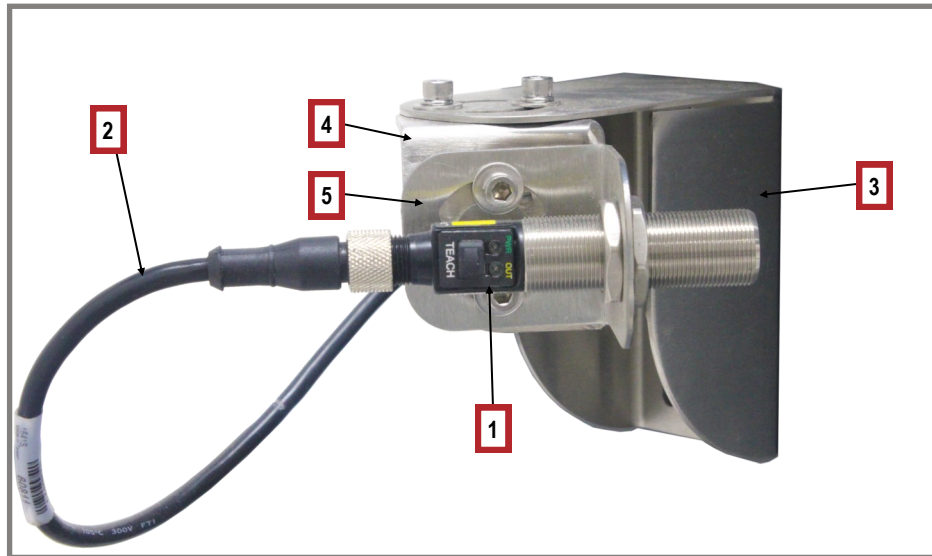

Item	Part #	Description
1	1819-036	IR Temperature Sensor
2	1819-033	Cable
3	8701-763	Base Mount
4	8701-762	Pivot Bracket
5	8701-761	Temp Sensor Mounting Angle

Revised 11/22

NOTES



HEAT SEAL

— QUALITY MADE IN THE USA —

