



Wrapper Cradle Mount 625ES



HEAT SEAL OFFERS THE INDUSTRY'S ONLY CERTIFIED ENERGY SMART OVERWRAPPER

Features

- Heats FAST, for On-Demand Wrapping
- Lightweight, Portable Design
- Experience 80% more Energy Efficiency
- Easy Maintenance - No Expertise Required!
- Local Utility Rebates may be available



Model Specifications

Model	625ES
Film Mount	Cradle System
Film Capacity	18" Maximum Roll Width, 8" Maximum Roll Diameter
Seal Plate	6" x 15"
Overall Dimensions	26.00"D x 20.50"W x 5.00"H
Electrical Specifications	120V, 60Hz, 162 Watts
Seal Plate Temperature	350°F
Weight	12 LBS
Other Features	No Assembly Required, Maintainable, Quick Film Changeover
Comparable To	600A / 700ES





Wrapper Cradle Mount 625ES

Common Replacement Parts & Part No.	
Seal Plate	6340101
Film Cutoff Rod	1824034
Photo Eye	1872168
Circuit Board	1818060

Indicator Light (Outside)

- Amber: Heating
- Red: Ready To Seal
- Green: Holding Temperature
- Flashing Red: Seal Plate Error

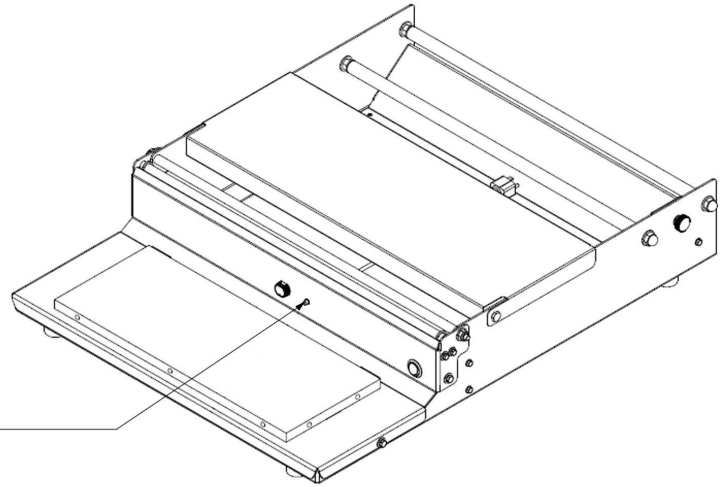

LED Light (red/amber/green)

Indicator Light (Circuit Board)

Green: Working, No issues

No Light OR Flashing Green: Circuit Board has no power. Check electrical box and make sure Power is ON

Unplug Photo Eye and IR sensor. If problem persists, replace circuit board. Otherwise, replace photo eye and/or hot plate.

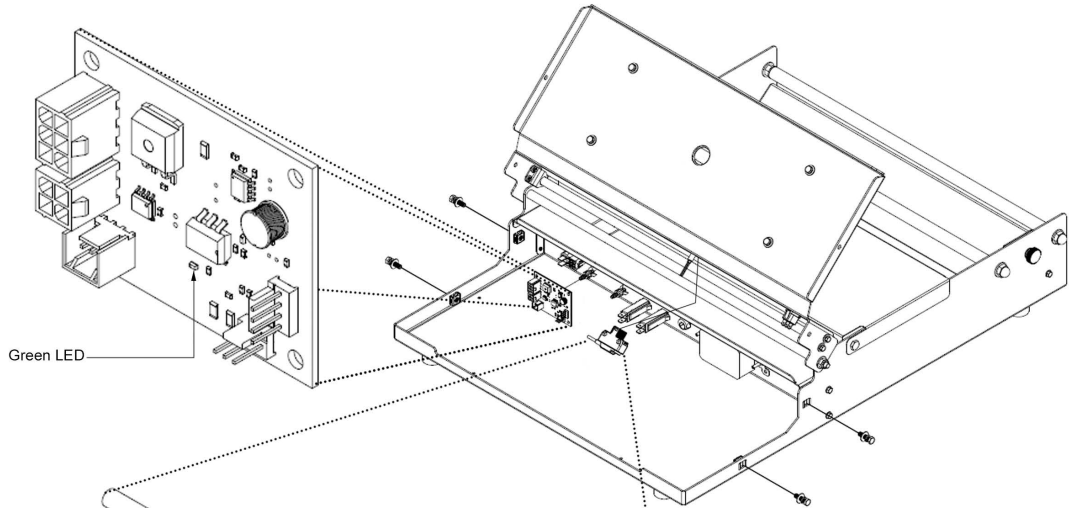

Green LED

Indicator Light (Photo Eye)

- Green: No issues
- Amber: Photo Eye is active

No Light: No power. If the light on the circuit board is green, replace photo eye

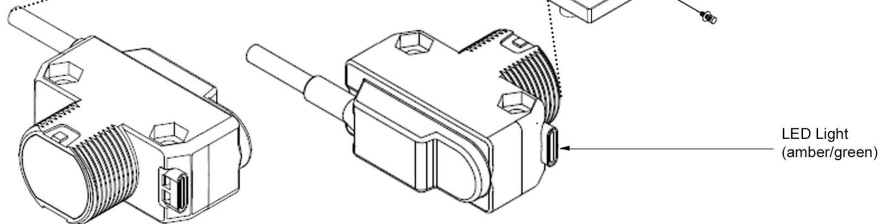

LED Light (amber/green)

