

TYP 6 PLCS
BAG AND TAG
LOOSE HARDWARE

ITEM	QTY	PART NUMBER	DESCRIPTION
10	16	1903-792	SCR, SHEET METAL, HEX WASH HD, SS, #12 x 1/2
9	33	1909-002	WASHER, FLAT, SS, 5/8 OD X 1/4 ID X .065 THK
8	33	1907-001	LOCKWASHER, SPLIT, 1/4 MED, SS
7	33	1903-045	SCR, CAP, HEX HD, SS, 1/4-20 X 3/4 LG
6	4	2115-001	CASTER, SWIVEL, STEM TYPE, 3" W/BRAKE
5	2	5820-116	SIDE CHANNEL, LEG KIT
4	4	5820-114	GUSSET PLATE, LEG KIT
3	1	5821-094	BOTTOM SHELF, LEG KIT, T2016
2	2	5821-093	FRONT/REAR CHANNEL, LEG KIT, T2016
1	4	5820-107	CORNER, LEG KIT HSE

Material Specification
HEAT SEAL/AMPAK
CLEVELAND, OHIO 44125

CONFIDENTIAL
THIS PRINT IS PROPERTY OF, AND DISCLOSES PROPRIETARY INFORMATION OF HEAT SEAL. IT IS LOANED FOR REFERENCE ONLY, AND MAY NOT BE REPRODUCED OR FORWARDED ELECTRONICALLY IN ANY MANNER, OR ITS CONTENTS DISCLOSED TO OTHERS, WITHOUT THE EXPLICIT WRITTEN PERMISSION OF OWNER AND MUST BE DESTROYED UPON REQUEST.

UNLESS OTHERWISE SPECIFIED:	CREATED: 7/28/2016
ALL DIMENSIONS IN INCHES	CREATED BY: MABBOTT
STANDARD TOLERANCES:	CHECKED:
0.00: ± .010	CHECKED BY:
0.000: ± .005	
ANGLE: ± 1'	

DESCRIPTION:	
T2016 LEG KIT	
DRAWING NUMBER:	REVISION:
5821-087	0
SIZE: D	SCALE: NONE
SHEET: 1	OF: 2

8 7 6 5 4 3 2 1

SECTION A-A

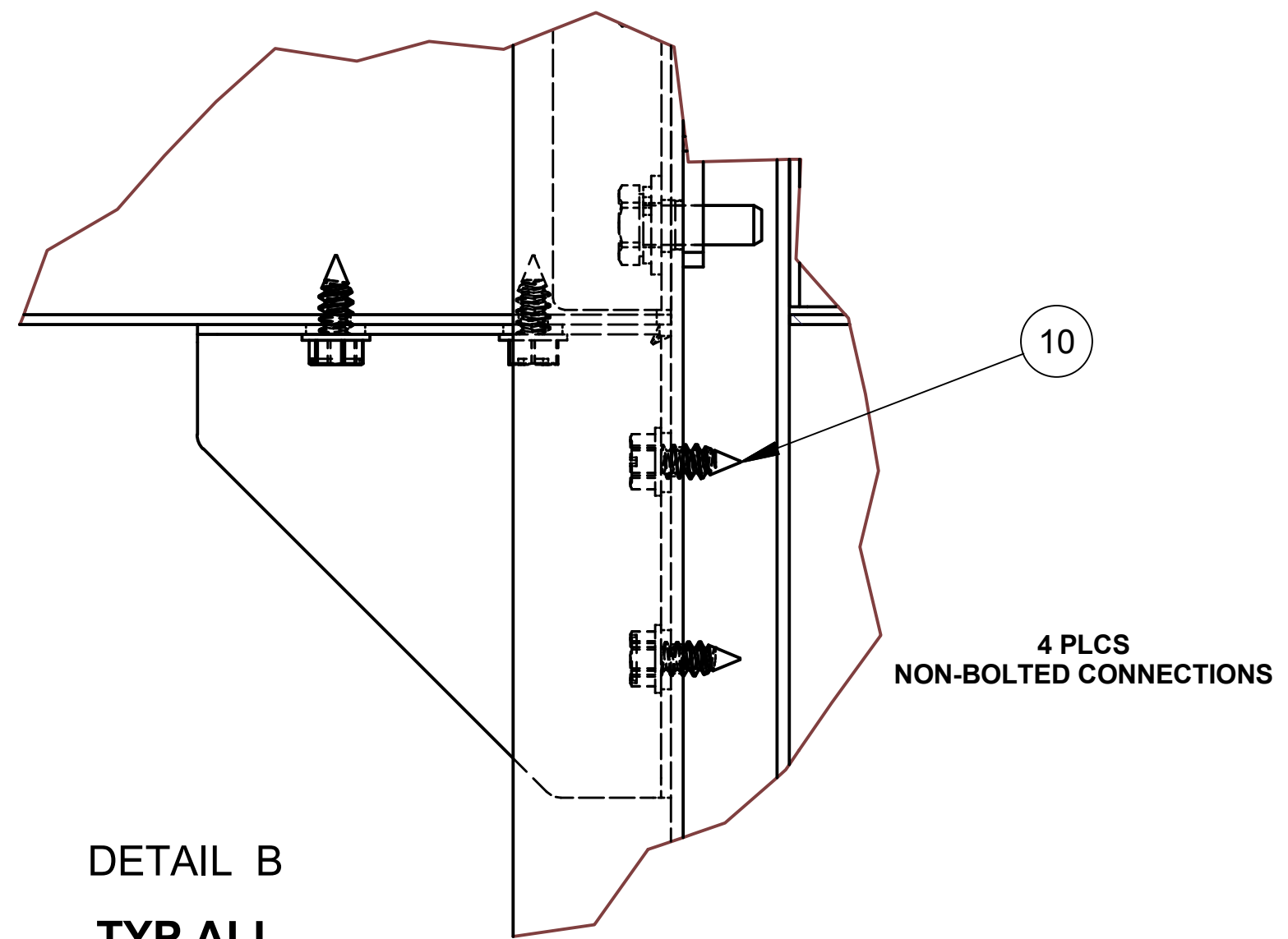
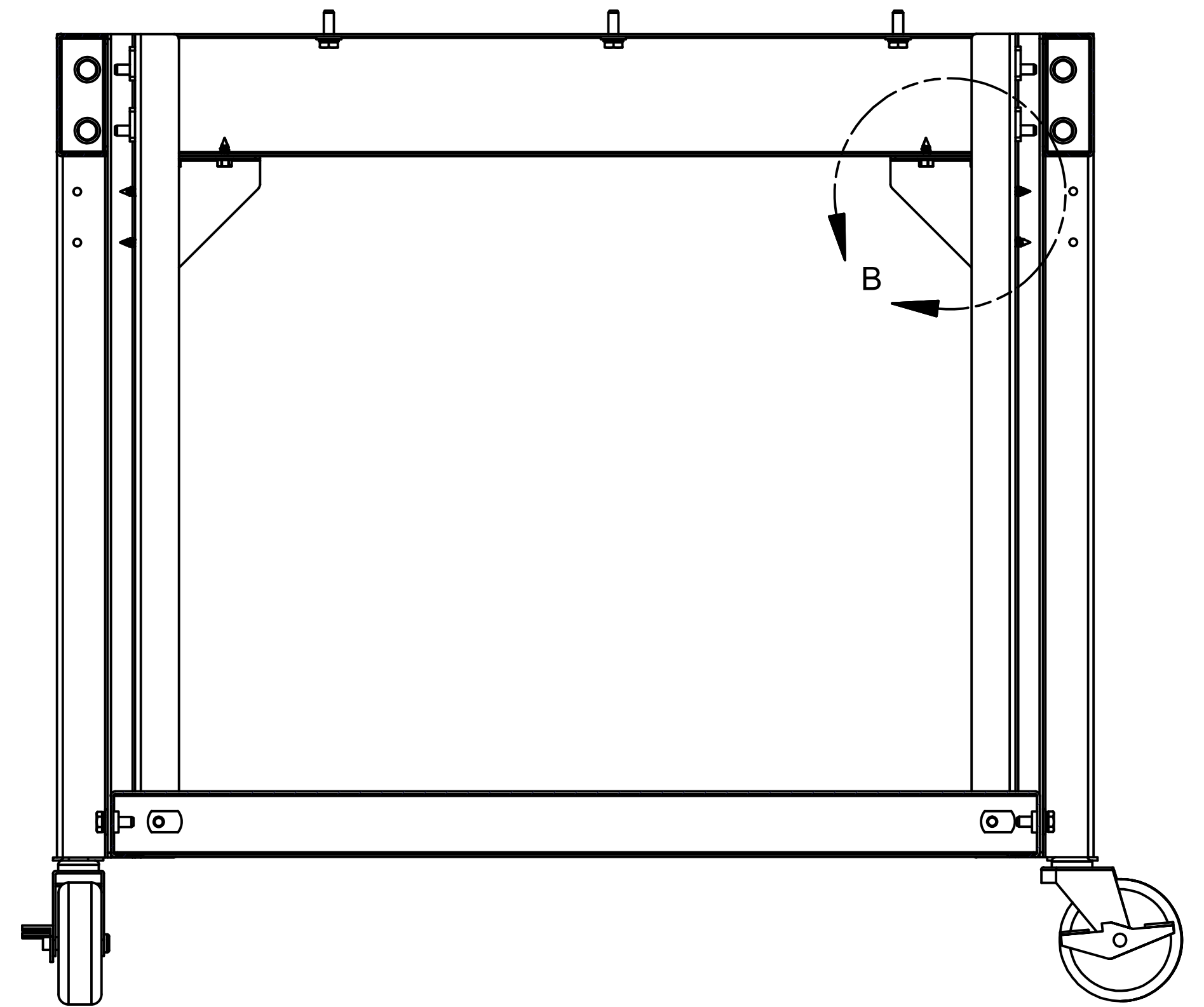

DETAIL B
TYP ALL
GUSSET PLATES

4 PLCS
NON-BOLTED CONNECTIONS

C B A

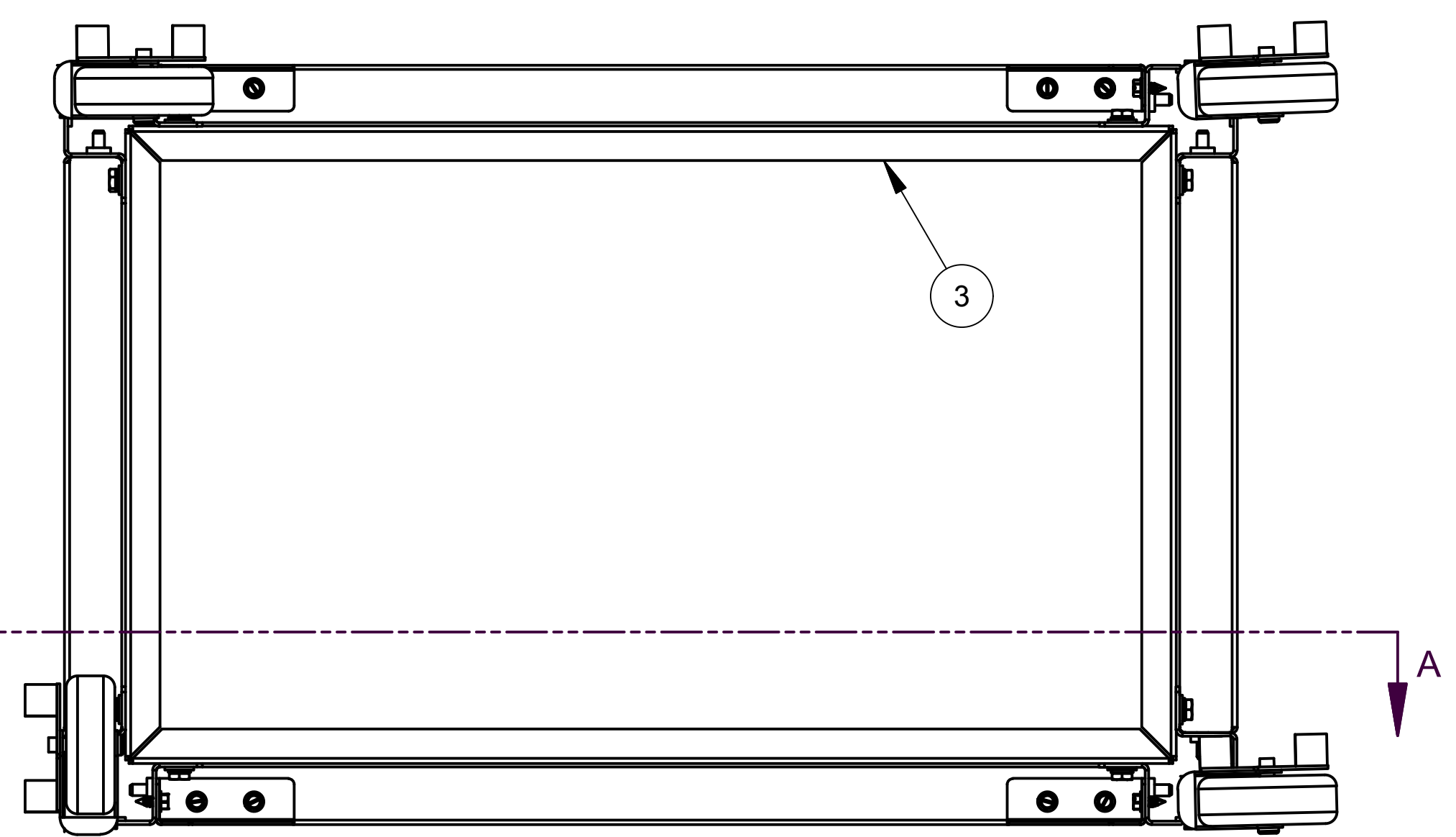

BOTTOM

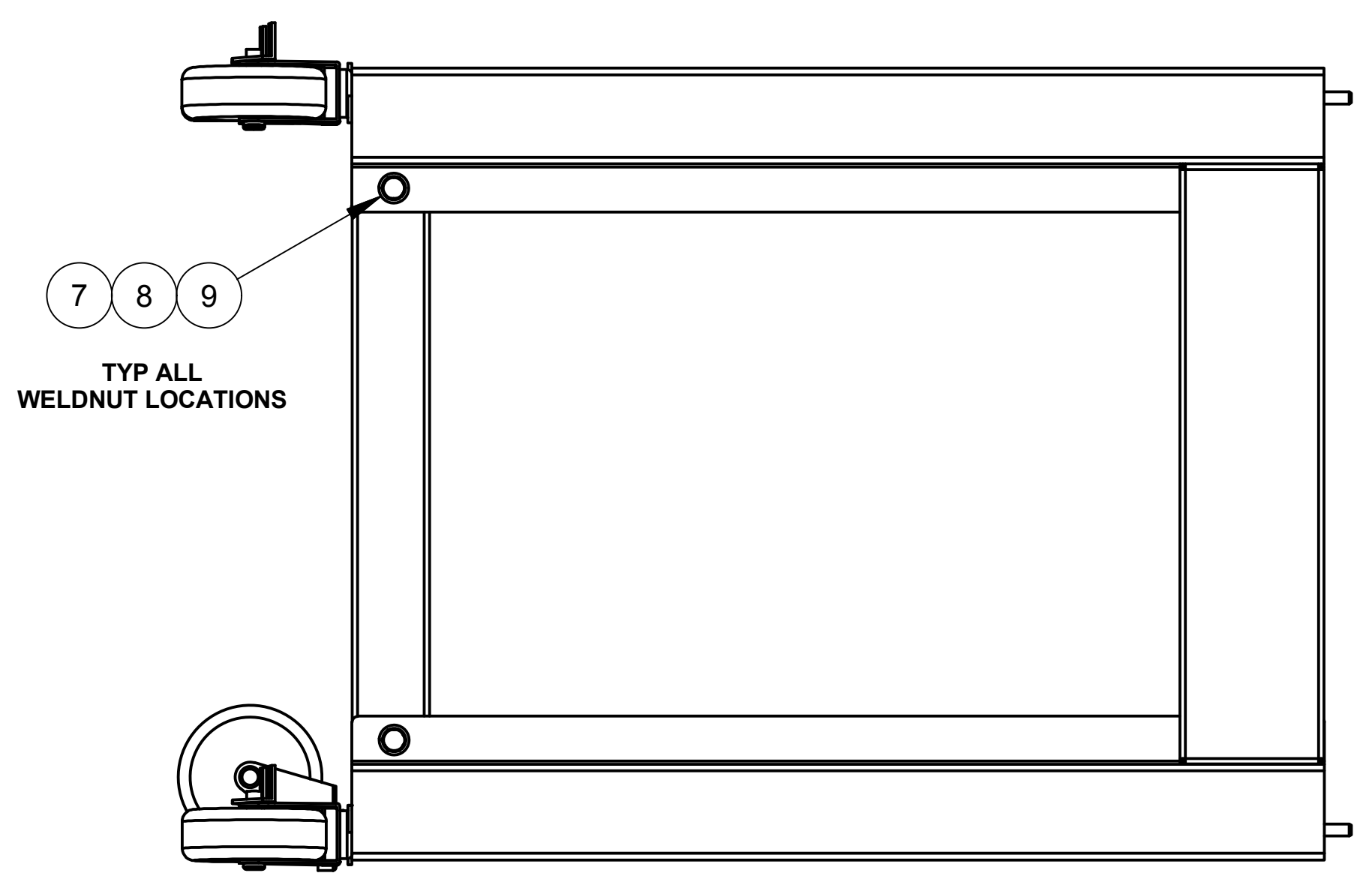

7 8 9
TYP ALL
WELDNUT LOCATIONS

A

HEAT SEAL/AMPAK
CLEVELAND, OHIO 44125

CONFIDENTIAL
THIS PRINT IS PROPERTY OF, AND
DISCLOSES PROPRIETARY INFORMATION
OF HEAT SEAL. IT IS LOANED FOR
REFERENCE ONLY, AND MAY NOT BE
REPRODUCED OR FORWARDED
ELECTRONICALLY IN ANY MANNER, OR ITS
CONTENTS DISCLOSED TO OTHERS,
WITHOUT THE EXPLICIT WRITTEN
PERMISSION OF OWNER AND MUST BE
DESTROYED UPON REQUEST.

DESCRIPTION: T2016 LEG KIT		REVISION: 0
DRAWING NUMBER: 5821-087		
SIZE: D	SCALE: NONE	SHEET: 2 OF: 2

8 7 6 5 4 3 2 1